



Allspeeds Limited

Royal Works
Atlas Street
Clayton Le Moors
Accrington
Lancashire BB5 5LP
England
Tel 01254 615100
Fax 01254 615199

CABLE CUTTER, TYPE HCV 120

PRODUCT CODE No. 980-288

**INSTRUCTIONS FOR INSTALLATION,
OPERATION & MAINTENANCE**

ISSUE 1 - 5th MAY 1998



KOPP **TANGYE** **John Blake** **WEBTOOL**



Registered Office as above Registered No. 647654 England

1. DESCRIPTION

The HCV120 Cutter is a lightweight cutting tool for umbilical/electrical cables, and is capable of operating remotely powered hydraulically, in a sub-sea environment. It may be mounted on an ROV or manipulator arm.

The cable to be cut is retained between an anvil and cutting blade, the anvil can be automatically withdrawn to allow placement.

2. CUTTING CAPACITY

The HCV120 cutter is primarily intended for cutting soft materials such as umbilical cable, communications cable and electric power lines (inc. double row armoured cable) upto 120mm in diameter. It is not intended for use on high tensile wire rope, chain or solid steel bar.

Where diameters smaller than 120mm are to be cut, place the material as near to the middle of the anvil as possible to minimise offset loading.

N.B. If In Doubt About The Size And Type Of Material To Be Cut Please Refer To The Manufacturer. Failure To Do So May Result In Permanent Damage To The Tool.

3. INSTALLATION

3.1 Four holes are provided in the tool body which can be used for any attachment necessary to mount the tool to an operating arm/vehicle. (See fig. 1.2. for dimensions)

3.2 Two hydraulic supplies are required, one at 640 Bar, usually through an intensifier, for the main ram and another at 190 Bar max. for the auxiliary cylinders. (The main ram return is rated and tested for 640 Bar but may be operated from the low pressure supply if this is more convenient). The maximum working pressures and port tappings are shown in *Table 1* below. Note that pressure limiting valves should be fitted to the hydraulic pressure supply to prevent over pressure at the tool.

Table 1.

Operation	Max. Working Pressure		Swept Volume (ml)	Port Tapping
	(Bar)	(psi)		
Main Ram Working Stroke	640	9,280	785	$\frac{1}{4}$ " NPT
Main Ram Return Stroke	640*	9,280	385	$\frac{1}{4}$ " NPT
Auxiliary Cylinder Out Stroke (To Retract Anvil)	190	2,750	30	$\frac{1}{4}$ " NPT
Auxiliary Cylinder In Stroke (To Reset Anvil)	190	2,750	20	$\frac{1}{4}$ " NPT

* N.B. Actual Pressure Required To Return Ram < 15 Bar (\approx 215 p.s.i.)

4. SAFETY

In all cases, where an operator is present, the following safety aspects must be reviewed before the cutting operation is initiated.

Always Ensure:

- : that the tool, hoses, couplings and pump are in good condition and are properly connected.
- : that the cable being cut is not under tension.
- : that the operator is shielded from the cutting blade during the cutting operation, especially when cutting near the end of a cable, as pieces of cable can be expelled from the tool.

5. OPERATION

- 5.1 Operate the auxiliary cylinder outstroke to retract the anvil. This clears access for the cutter to be placed over the cable.
- 5.2 Place the cutter over the cable so that the cable is as far into the cutter as possible. This will ensure that the cable does not foul the anvil when it is reset.
- 5.3 Operate the auxiliary cylinder instroke to reset the anvil fully home underneath the cable.
N.B. It Is Important That The Auxiliary Cylinders Are Fully Stroked At This Stage As Permanent Damage Will Result If The Anvil Is Not Fully Engaged.
- 5.4 Operate the main ram downstroke to cut the cable. When this is done retract the main ram until it is fully returned.
- 5.5 If a further cut is required, the above procedure should be repeated.
N.B. Do Not Operate The Auxiliary Cylinders When The Main Ram Is Fully Extended As This Will Damage The Blade And The Anvil.

6. AFTER USE

If the tool has been used in a marine environment it should be hosed down with clean water, allowed to drain and sprayed externally with a de-watering fluid. Before storage inspect the general condition of the tool. Attention should be paid to the anvil and blade in particular. The anvil should be clean and free from any damage or bruising on the outside diameter that would prevent it retracting properly. The blade edge should be smooth and free from any serrations. Note that a slight ripple to the blade edge is acceptable and will not cause any problems. Any minor damage can be smoothed off with an oil stone where necessary.

7. SERVICE

It is unlikely that service should be required on the hydraulic components of the tool under normal circumstances, however spare seal kits are available if required.

The blade and anvil are the only parts that require intermittent replacement, depending on the frequency of use and the materials being cut. These parts can be ordered as spares using the part reference numbers in Table 2, in addition please quote the tool serial number.

Table 2.

Component	Part Number
Anvil	CC6483
Blade	705046
Seal Kit	995291

If required, the tool can be returned to the manufacturer at any time for servicing and testing. If servicing is undertaken by the user please follow the instructions in Section 6 '*Proof Tests*'.

8. PROOF TESTS

If at any time it is necessary to carry out proof tests on the tool, e.g. after service on the hydraulic cylinders the following procedure should be applied.

- 8.1 The proof test pressure is should not exceed 125% of the maximum working pressure.
- 8.2 The tool should be guarded during the proof test operation.
- 8.3 The proof test pressure should be applied gradually, by means of a hand pump, until the maximum test pressure is reached.

9. REPLACEMENT OF ANVIL AND BLADE

To remove the anvil and/or the blade, follow this procedure:

- 9.1 Disconnect the anvil (CC6483) from the anvil bracket (993013) by removing the spring pin (030820). The anvil can then be passed through the body and removed.
- 9.2 To remove the blade (705046), pump out the main ram until the three ¼" diameter blade-pins (030648) are accessible. Drift out the blade pins and slide the blade out of the tool.
- 9.3 To replace the blade/anvil reverse the above procedure.

PARTS LIST - Refer to Fig.1.1

PART No.	DESCRIPTION	Qty.
710-270	Body	1
728-066	Cylinder, main	1
764-087	Ram	1
774-020	Bearing ring	1
CC6483	Anvil	1
715-300	Bush, anvil guide	1
715-301	Bush, anvil	1
709-047	Block, sliding	2
765-177	Guide plate, blade	2
701-191	Adaptor	1
011-011	Bolt, clevis	4
011-015	Bolt, lever frame	1
020-512	Nut	1
035-061	Screw, sliding block	2
080-956	Washer	2
080-957	Washer	4
705-046	Blade	1
025-570*	Scraper, ram	1
025-756*	'O' ring	1
025-803*	Seal, main cylinder	1
025-804*	Seal, ram	1
035-062	Screw, socket set	1
035-080	Screw, sock set	2
035-064	Screw, socket cap	16
030-648	Pin, spring, blade	3
030-820	Pin, spring, anvil	1
982-114	Cylinder, lever	2
993-013	Frame, lever	1
993-011	Bracket, anvil	1

N.B. Parts Marked Thus * Are In Seal Kit

PARTS LIST - Refer to Fig.2.1

PART No.	DESCRIPTION	Qty.
709-605	Piston block	2
728-048	Cylinder, lever	2
SSC-6476	End cap	2
764-102	Piston	2
026-701	Pellet, Aluminium	1
025-311*	O' ring, end cap	2
025-569*	Scraper, rod	2
025-801*	Seal piston	2
025-802*	Seal, rod	2
035-062	Screw, socket set, piston block	2
035-063	Screw, socket cap	8

N.B. Parts Marked Thus * Are In Seal Kit

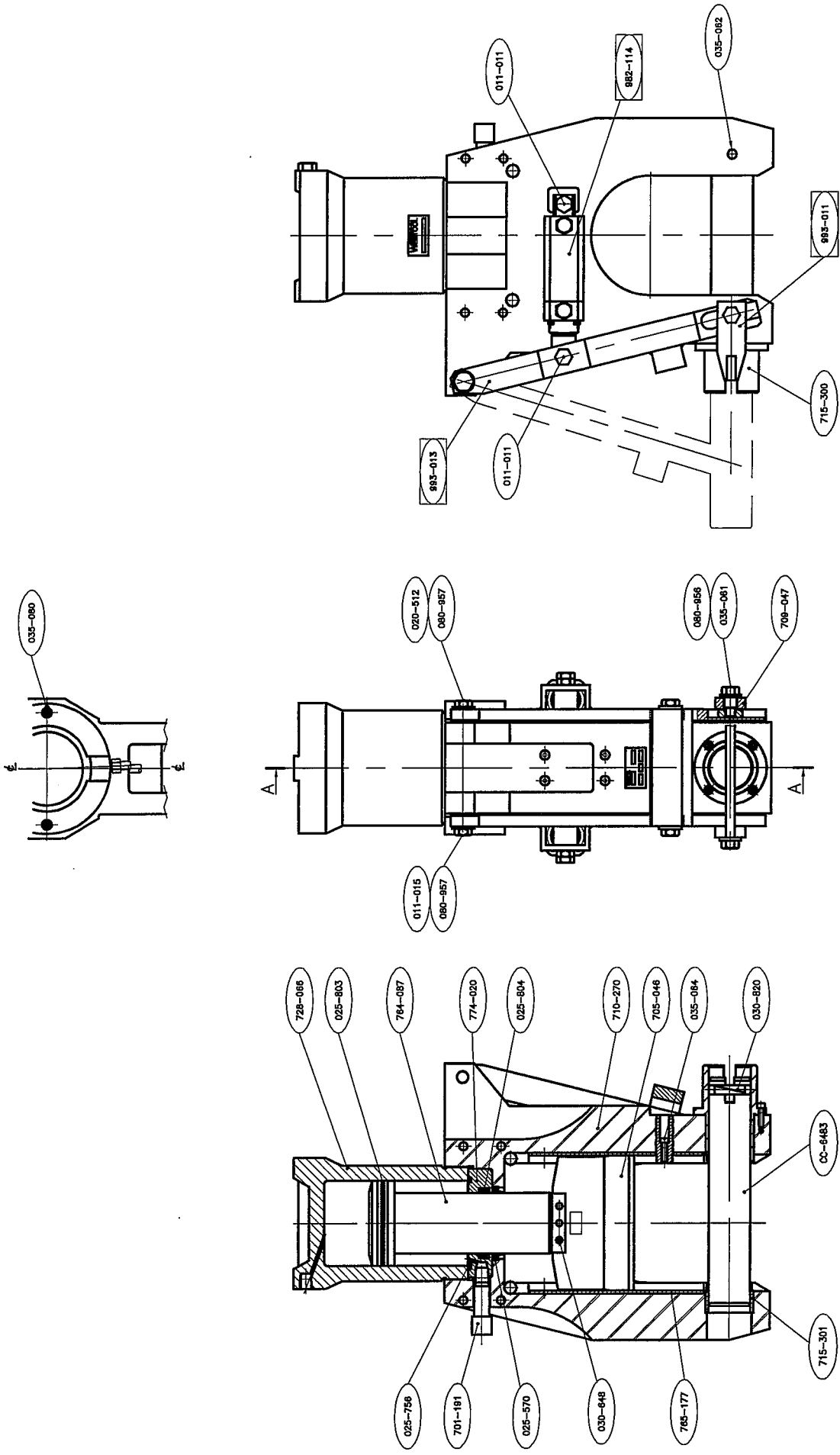

Fig. 1.1

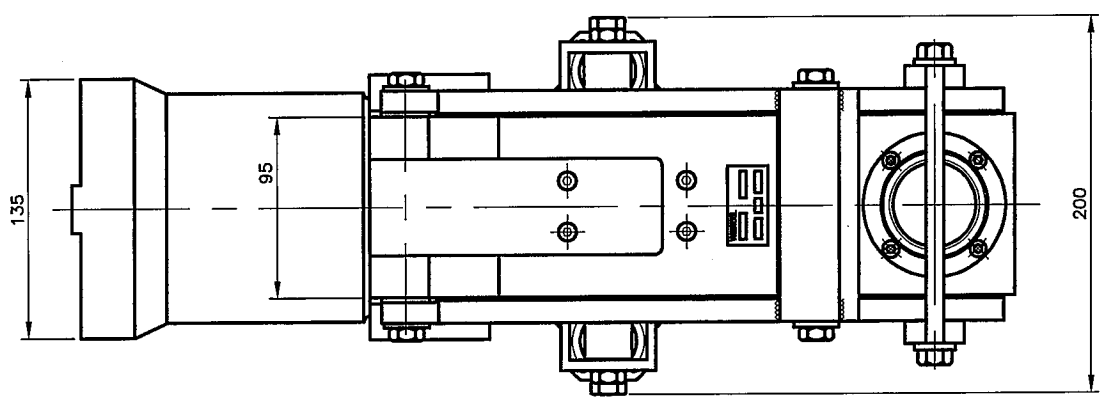
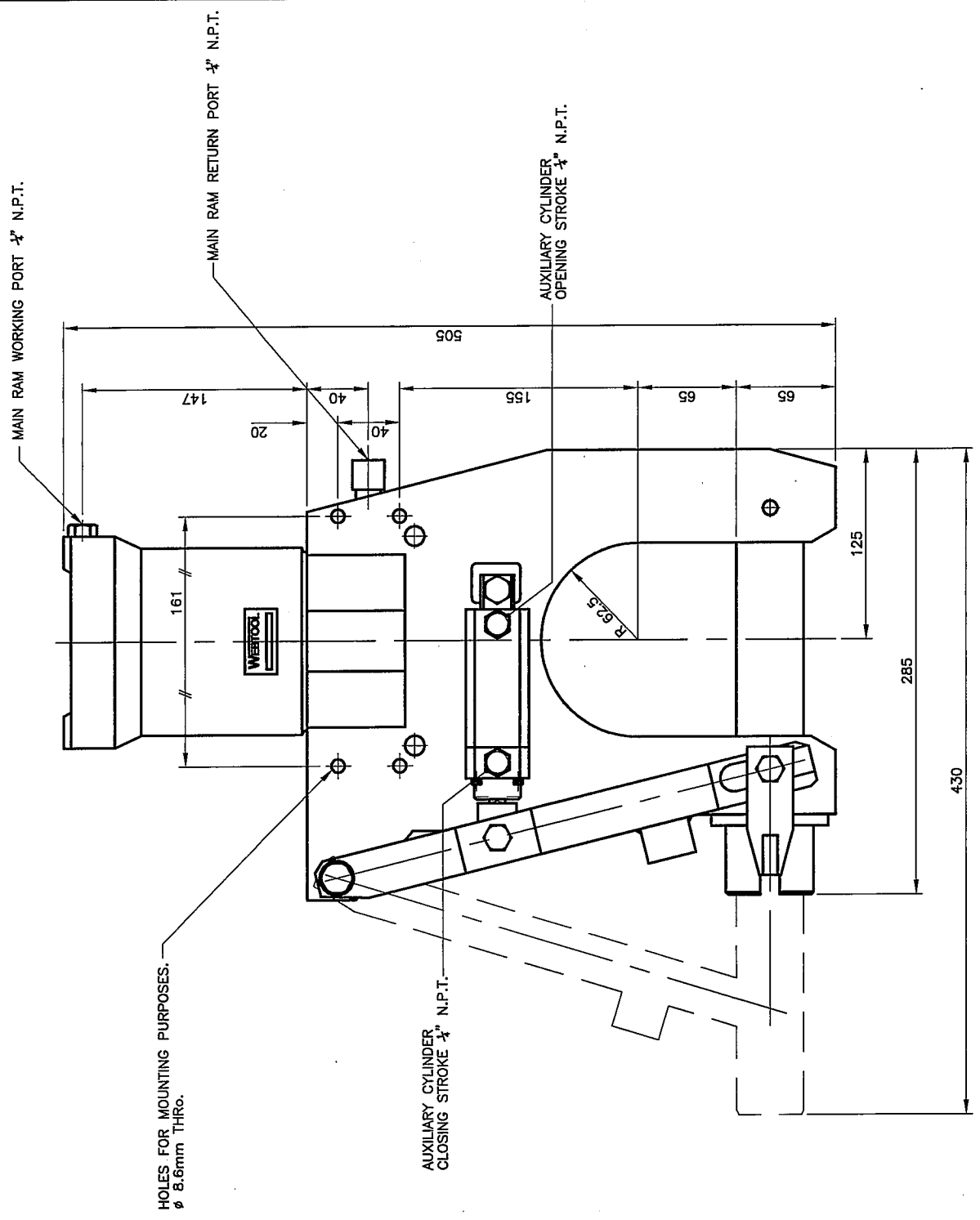

Fig. 1.2

Auxiliary Cylinder: 980-114

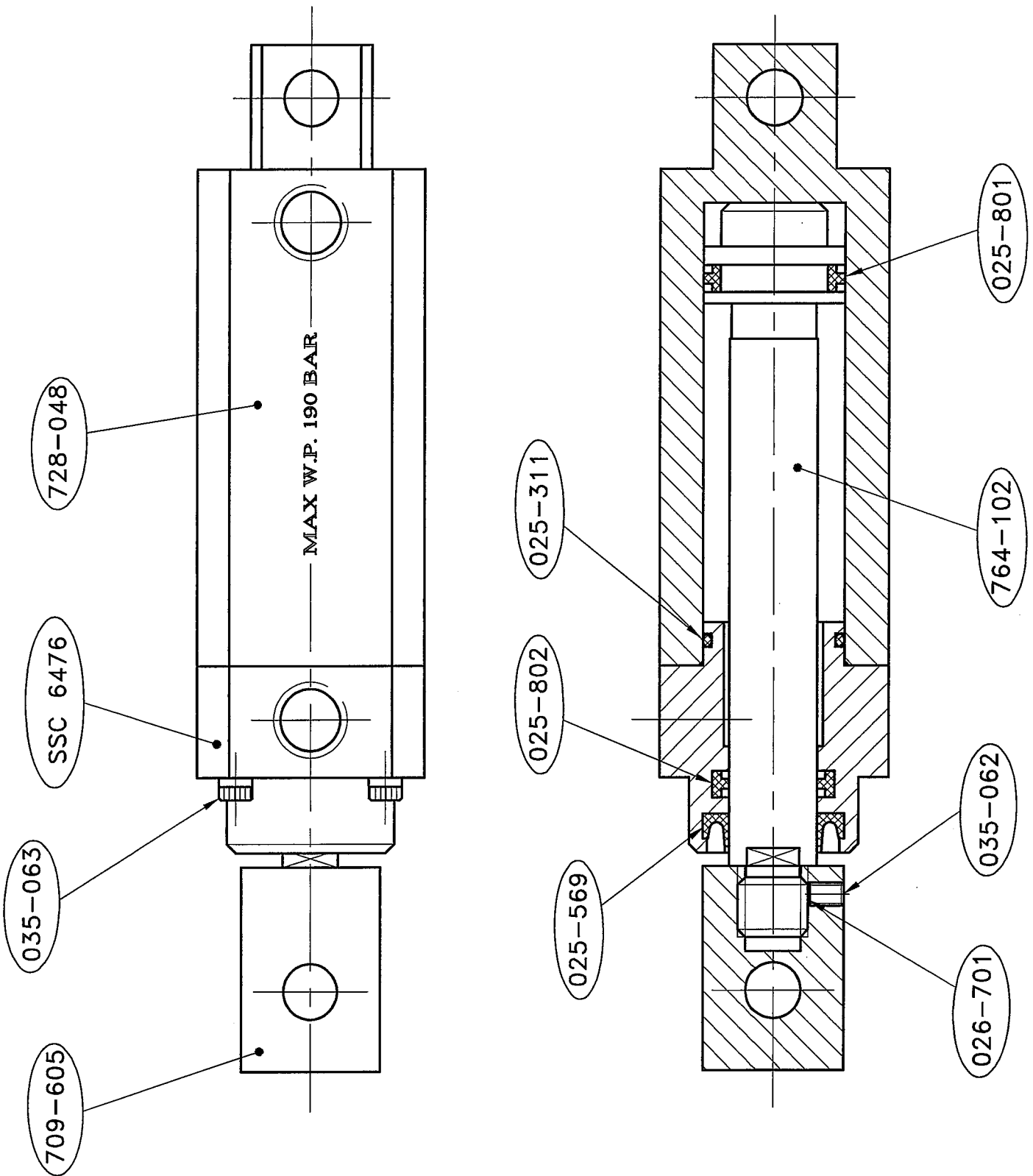

Fig. 2.1