

WEBTOOL – VARIATORS LTD.

61 Advance Rd Unit 7
Toronto, Ontario M8Z 2S6, CANADA
Tel: (416) 234-8671, Fax: (416) 237-9279
www.webtool-subsea.com

WEBTOOL
HCV270 CUTTER

PRODUCT CODE No. 980-216

INSTRUCTIONS FOR INSTALLATION,
OPERATION & MAINTENANCE

Issue 2 – July 2002

1. INSTALLATION

- 1.1 Tapped holes, 5/8" UNC, are provided in the tool body, see Fig. 1, which can be used for any attachment necessary to mount the cutter.
- 1.2 Two hydraulic supplies are required, ported as shown in Fig. 2. The maximum working pressures are shown in *Table 1* and pressure limiting valves should be fitted into the supply to limit the pressures to these levels.

TABLE 1.

Function	Max. Working psi	Pressure bar	Swept Volume ml. (U.S. gallon)	Port Tapping
Main ram working stroke.	10,000	690.00	5300 (1.40)	3/8" NPT
Main ram return stroke.	10,000*	690*	1910 (0.51)	3/8" NPT
Auxiliary cylinder out stroke. (To retract anvil)	2,750	190	132 (0.035)	1/4" NPT
Auxiliary Cylinder Instroke. (To reset anvil)	2,750	190	TOTAL 81 (0.021)	1/4" NPT

* N.B. Actual Pressure Required To Return Ram < 200 P.S.I. (14 bar)

2. CUTTING CAPACITY

The cutter is intended for use on coflexip type riser and will cut hose up to 270 mm diameter. It may be used on alternative materials; such as electrical power or communication cables, up to a maximum of 150 mm diameter. Where small diameters are to be cut, effort should be made to place the material centrally along the anvil to minimise offset loading. The cutter is not designed to cut wire rope.

If it is required to extend the range of the cutter, for instance to cut solid bar members of steel, please refer to the manufacturer with full details of size and tensile strength. Failure to do so may result in damage to the anvil and blade.

3. OPERATION

- 3.1 Prior to use, the auxiliary cylinder outstroke should be operated to withdraw the anvil. This clears access for the cutter to be placed over the hose.
- 3.2 Place the cutter over the hose. Ensure that the hose is as far into the cutter as

- 3.3 Operate the auxiliary instroke to position the anvil fully home under the hose. Be sure that the auxiliary cylinders are operated to the full extent of their stroke.
- 3.4 Operate the main ram downstroke to sever the hose. When this is done, retract the main ram until it is fully home.
- 3.5 If a further cut is required, the above procedure should be repeated.
N.B. Do not operate the auxiliary cylinders when the main ram is fully extended since this would damage the anvil.

4. AFTER USE

When the tool is retrieved, it should be hosed off with clean water, allowed to drain and sprayed externally with a de-watering fluid. Before storage, inspect the general condition of the tool. Attention should be paid to the anvil and blade in particular. The anvil should be clean and free from any damage or bruising on the outside diameter that would prevent it from retracting properly. The blade edge should be smooth and free from any serrations. Note that a slight ripple to the blade edge is acceptable and will not cause problems. Any minor damage can be smoothed off with an oil stone if necessary.

5. SERVICE

It is unlikely that service would be required on the hydraulic components of the tool under normal circumstances, but a seal spares kit is available if required. The only parts that would need intermittent replacement would be the anvil and blade, this depending on the frequency of use and materials being cut. These parts can be ordered up on the following spares reference numbers, but in addition please quote the tool serial number.

Seal Kit	Part Number 995 288
Anvil	Part Number SSC 6488
Blade	Part Number 705 050

If required, the tool can be returned to the manufacturer at any time for servicing and testing. If servicing is undertaken by the user, see note on proof testing under SAFETY. (See section 6)

6. SAFETY

Whilst the tool is intended for remote operation sub-sea, there is no reason why it should not be used above surface and be powered by a suitable hand pump.

- 6.1 In all cases, where an operator is present, the safety aspects must be reviewed before cutting operation is commenced.

- 6.2 *i.* Ensure that the tool, hoses and pump are in good condition and properly connected.
- ii.* No attempt should be made to cut material that is under tension.
- iii.* Ensure that the operator is shielded from the cutting blade during the cutting operation. When cutting the very end of a hose, individual cut wires can be expelled from the tool, so ensure that the operator is shielded from these.
- 6.3 If at any time it is necessary to carry out proof tests on the tool, e.g. after service on the hydraulic cylinders, the following applies.
- i.* The proof test pressure is 770 bar for main cylinder cutting stroke and 240 bar for main cylinder return stroke and auxiliary cylinders.
- ii.* The tool should be guarded during the proof test operation.
- iii.* The proof pressure should be applied gradually, by means of a hand-pump, until the maximum pressure is reached.

7. REPLACEMENT OF ANVIL

Extend the auxiliary cylinders so that the lever arm 765212 exits the guide bush 715348. Loosen the 8 off M6 screws holding pivot pin housings 749045A & B. Also loosen the M6 retaining screw 035073. Withdraw the pivot pin 761267 far enough to release the lever arm. (There is an M6 tapped hole in the end of the pivot pin to assist in this)

The lever arm can be moved upwards to separate it, and the anvil pin 761247, from the anvil SSC6488. The anvil may now be slid out from the guide bush. Re-assembly is the reverse of the above process.

8. REPLACEMENT OF CUTTING BLADE

First withdraw the anvil as described in 7 above. Pump out the main ram until the blade retaining pins 030636 can be seen in the opening of the cutter body. the three pins are ¼" (6.35 mm) diameter and they should be knocked out enough to release the blade.

9. REMOVAL OF MAIN CYLINDER

If it is necessary to renew the hydraulic seals, the cylinder must be removed from the tool. As an aid to this, 2 off tapped holes are machined in the cylinder end face. These are M10 x 12 deep on 130 mm centres. To use these holes first remove the blanking screws, and fasten a piece of 30 x 10 or similar flat bar (x 900 long) centrally to the top of the cylinder. this can be used to loosen or re-tighten the cylinder.

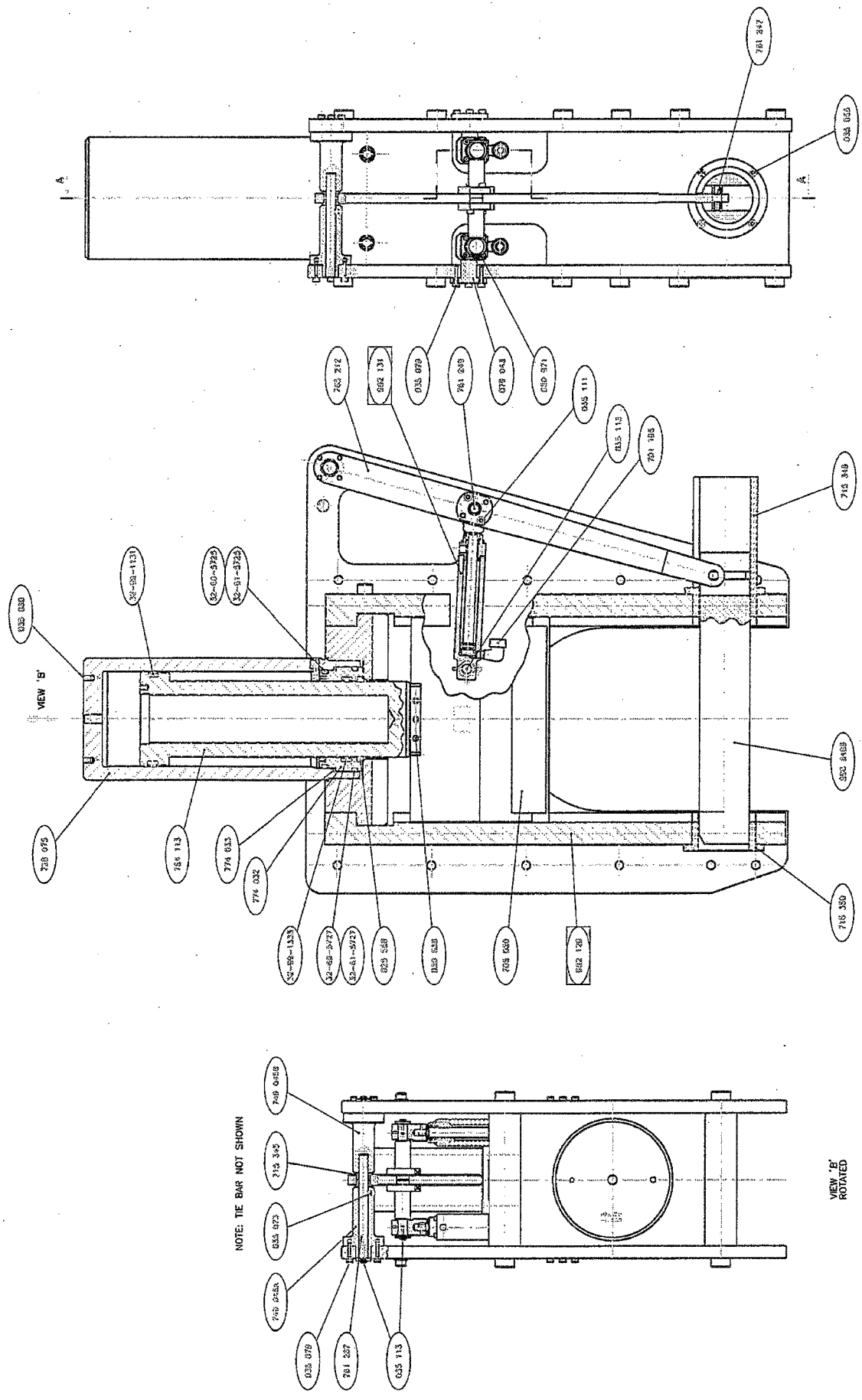

CABLE CUTTER HCV 270 - ASSEMBLY		DATE 13-4-67-87
DESIGNER	WORK LOANS APPROVED	DRG. NO. 980 216
SCALE	1:2 BICYCLE 1 OF 1	
SEE ITEM ORGS		
MATL. GRADE		
DATE		
SPEC.		
W/T.		
1	1	
2	1	

Fig. 1.

