

RCO40 - Wire Rope Cutter Part No - 980502

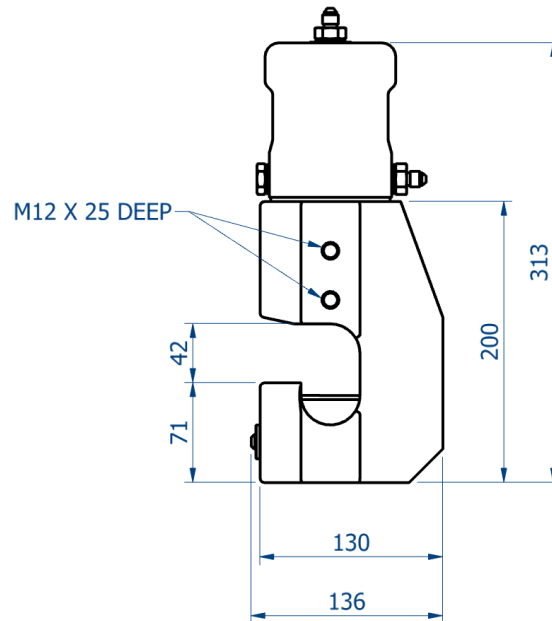

- Heavy duty wire rope cutter designed for use in severe working conditions
- Open sided design allows for easy positioning of the cutter on the cable
- Blade shaped anvil cuts higher grade cable
- Corrosion resistant stainless steel body with Nitrotec coated alloy steel cylinder
- Long blade and anvil life ensures that tool maintenance is kept to a minimum
- Ideal for operation in confined spaces
- Optional hydraulic intensifier panel is available
- Can be used at any water depth
- Cutting Capacity - Steel wire ropes up to $\varnothing 38\text{mm}$ (1.5") with a maximum tensile strength of 1960N/mm². Individual wire strands must be a minimum of $\varnothing 1.5\text{mm}$ (1/16")
- Suitable for cutting wire rope, cables and umbilicals
- 700 bar maximum input pressure
- Supplied with 10k rated JIC No 4 fittings
- Approx weight in air – 17kg
- Approx weight in water – 15kg
- Swept volume cut stroke – 0.15 litres
- Swept volume return stroke – 0.1 litres

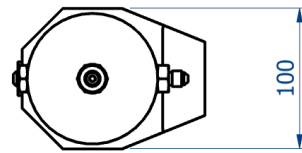

PHONE: 1.416.234.8671 **FAX:** 1.416.237.9279

EMAIL: info@webtool-subsea.com

61 Advance Rd., Unit 7, Toronto,
Ontario, Canada M8Z 2S6

WEBTOOL-SUBSEA.COM

allspeeds

Webtool is a Trademark of Allspeeds Ltd
Designed and Manufactured in the UK