

WCS75HDZ - Wire Rope Cutter Part No - 980482

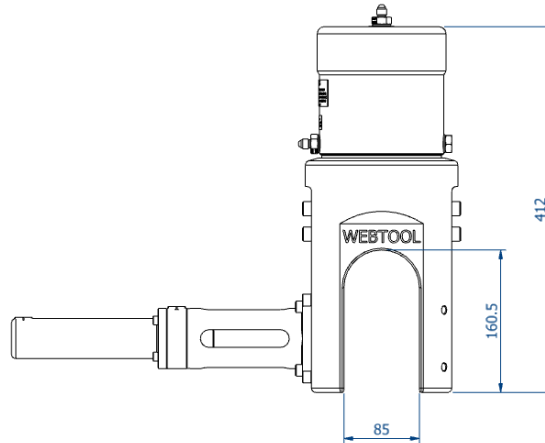

- Heavy duty wire rope cutter designed for use in severe working conditions
- Hydraulic anvil allows for easy positioning and operation by ROV
- Corrosion resistant stainless steel construction
- Long blade life ensures that tool maintenance is kept to a minimum
- Optional intensifier panel is available
- Can be used at any water depth
- Approx weight – 45kg
- Cutting capacity – Maximum $\varnothing 75\text{mm}$ wire rope of $1770\text{N}/\text{mm}^2$ grade (IPS)
- Note - For cutting higher grades of wire (EIPS and EEIPS) we recommend the use of the RCV75HD cutter
- Suitable for cutting wire rope, cables and umbilicals
- 700 bar main cylinder pressure
- 210 bar auxiliary cylinder pressure
- Standard tool is shown above. Bespoke and custom designs to suit special applications are available on request

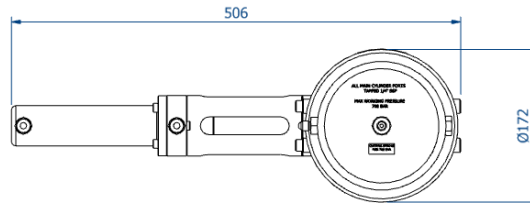
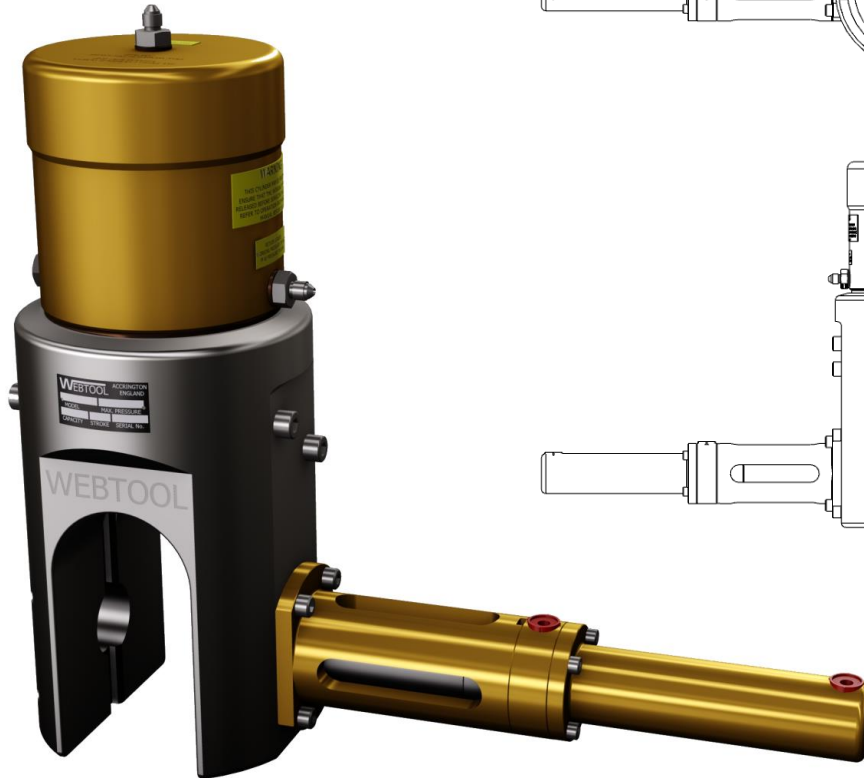

PHONE: 1.416.234.8671 **FAX:** 1.416.237.9279

EMAIL: info@webtool-subsea.com

61 Advance Rd., Unit 7, Toronto,
Ontario, Canada M8Z 2S6

WEBTOOL-SUBSEA.COM

allspeeds
www.allspeeds.co.uk

Webtool is a Trademark of Allspeeds Ltd
Designed and Manufactured in the UK