



Allspeeds Ltd.
Royal Works, Atlas St
Clayton le Moors
Accrington
Lancashire
England
BB5 5LW

Tel +44 (0)1254 615100
www.allspeeds.co.uk

WIRE ROPE CUTTER RCV75HD

PRODUCT CODE No. 980235

**INSTRUCTIONS FOR INSTALLATION,
OPERATION & MAINTENANCE**

Revision 12 issue 1 Modification No. 20809 Date 17th March 2015

© Copyright Allspeeds Holdings Ltd.
This document must not be modified in any way.

Description

The RCV75HD is a double acting tool primarily intended for use on steel wire rope with a maximum tensile strength of 1770N/mm² up to 75mm (3") diameter. It may be used on alternative materials, such as electrical power or communication cables, again up to a maximum of 75mm (3") diameter.

1. **SAFETY**

Before operation, read and understand this operations manual.

Whilst the tool is intended for remote or local operation sub-sea, there is no reason why it should not be used above surface. Ensure that the tool, hoses and pump are in good condition and properly connected.

Ensure that suitable pressure regulation equipment is used and that the unit is not subjected to pressures higher than those stated in section 3.

In all cases, where an operator is present, the safety aspects must be reviewed before the cutting operation is commenced.

No attempt should be made to cut wire ropes or other material that is under tension. Ensure that the operator is shielded from the cutting blade during the cutting operation.

When cutting near the very end of hose or rope, individual cut wires can be expelled from the tool, please ensure that the operator is shielded from these.

CAUTION - Any modification made to this tool will invalidate the warranty and may lead to equipment failure or personal injury. If in doubt, please contact the manufacturer (Allspeeds Ltd) or an authorized distributor for assistance.

IMPORANT: Please note this tool is designed for intermittent subsea use. Please refer to the manufacturer (Allspeeds Ltd) or an authorised distributor should you wish to use this tool subsea for any period over **14 days**.

If at any time it is necessary to carry out proof tests on the tool, e.g. after service on the hydraulic cylinders, it must be returned to the supplier for testing where the following procedures apply.

The maximum proof test pressure should not exceed 125% of the maximum working pressure and this should only be done by Allspeeds using our specially adapted test rig.

The tool should be guarded during the proof test operation, and be carried out in a safe working environment.

The proof pressure should be applied gradually, until the maximum pressure is reached.

PPE is to be worn at all times when using this cutter (Gloves, Goggles and Safety Shoes as a minimum).

INSPECT THE TOOL BEFORE USE

With the cutter isolated from the hydraulic supply, check the condition of the blade edge. If the blade is damaged or blunt replace with a fresh blade before cutting. This procedure is described in section 8.

Ensure that care is taken when checking the blade as the edge may be sharp

Check the condition of the anvil. It is normal that the anvil will show an indent where the blade has pressed down into it. It can withstand multiple cuts, but any excessively damaged anvil should be replaced. This procedure is described in section 7.

CAUTION – USE OF BLADES AND PARTS NOT SUPPLIED BY WEBTOOL MAY RESULT IN TOOL FAILURE AND CONSEQUENTIAL DAMAGE

2. CUTTING CAPACITY

The cutter is primarily intended for use on steel wire rope, having a maximum tensile strength of 1770N/mm^2 up to 75mm (3") diameter. It may be used on alternative materials, such as electrical power or communication cables, again up to a maximum of 75mm (3") diameter. Where smaller diameters are to be cut, effort should be made to place the material centrally along the anvil to minimise any offset loading.

This cutter is not intended for use on chain or solid steel bar.

3. INSTALLATION

Four holes, M10x20mm deep, are provided in the tool body on each face (see sketch) which can be used to mount the cutter. The cylinder is a pressure vessel. It must not be used as a mounting point. The cylinder should not be drilled, machined, mutilated or damaged in any way. The warranty will be invalidated by such actions.

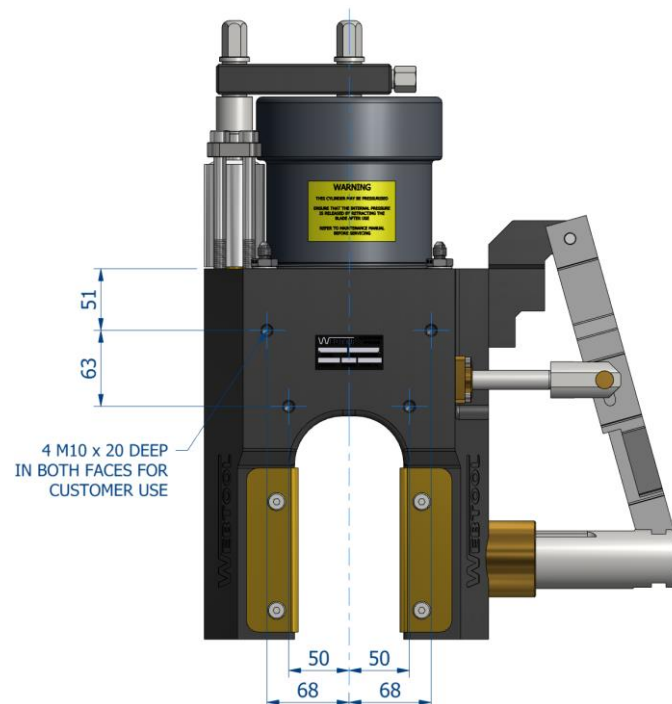

A hydraulic supply is required, ported as shown (see sketch).

IMPORTANT:- This tool should be connected to a valve pack or HPU with centre open valves, connection to centre closed valves could result in a dangerous condition or result in a dangerous tool breakage, this includes workshop testing and servicing.

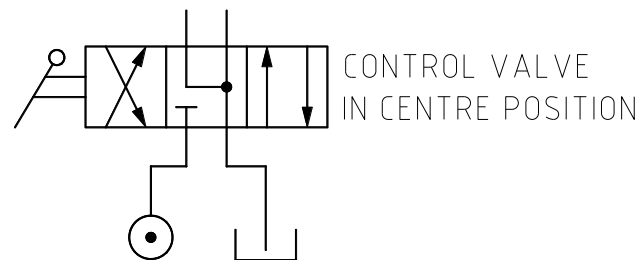

The maximum working pressures are shown in table 2 overleaf and pressure limiting valves must be fitted into the supply to limit the pressures to these levels. The cutter has a relief valve built in which will restrict the maximum output pressure to approx. 750 bar, the normal output working pressure should be 700 bar.

Do not operate auxiliary cylinder (anvil) unless main cylinder is connected to an open centre or centre float valve.

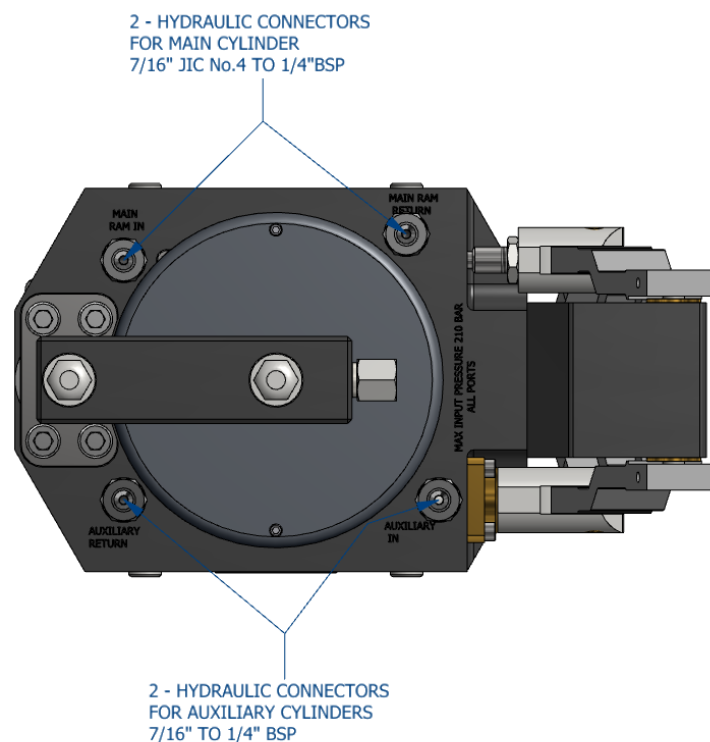

A relief valve should also be incorporated in the return line. This is to prevent excessively high pressures in the annular side of the hydraulic cylinders should the return to tank become blocked for any reason.

Good quality grade ISO32 mineral hydraulic oil such as Shell Tellus 32, or equivalent, is suitable for use in this tool.

IMPORTANT - It is critical that the correct grade and cleanliness of fluid is used with this tool as contaminated fluid may lead to system failure.

Whilst the RCV75HD does contain screens, these are only designed to stop large particles from accidentally entering the critical components and will not prevent system damage caused by the use of contaminated fluid.

The minimum fluid cleanliness levels are as follows:

Table 1

Fluid Type	ISO 4406:1999 Target Level	Filtration Rating (µm)
ISO 32 Hydraulic Oil	17/15/12	3

The performance and system life of this tool may be severely compromised and/or permanent damage may occur if contaminated fluid is used. If in doubt please contact Allspeeds Ltd or an authorised distributor.

IMPORTANT: This tool is fitted with a 4:1 intensifier and a relief valve which will limit the output pressure to a maximum of 750 bar.

Table 2

Function	Input Pressure		Cutting Pressure Generated		Swept Volume	
	psi	bar	psi	bar	ml	U.S. Gal
Working Stroke	2540	175	10,000	700	890	(0.197)
Return Stroke	3045	210	3,045	210	580	(0.130)
Auxiliary Cylinders	3045	210	3,045	210		

4. OPERATION

Before deployment, function test the tool and ensure that all operators are familiar with this procedure. ROV observation of the tool should be maintained at all time during operation.

Prior to use, ensure no damage has occurred to the blade or anvil.

The weight of the tool in air is: **43kg**

The weight of the tool in water is: **30kg**

IMPORTANT: Please note this tool is designed for intermittent subsea use. Please refer to the manufacturer (Allspeeds Ltd) or an authorised distributor should you wish to use this tool subsea for any period over **14 days**.

CAUTION – Any modification made to this tool will invalidate the warranty and may lead to equipment failure or personal injury. If in doubt please contact the manufacturer (Allspeeds Ltd) or an authorised distributor for assistance.

DEPLOYMENT

Hydraulically draw back the anvil. Place the cutter over the wire rope. Ensure that the wire rope is as far into the cutter mouth as possible.

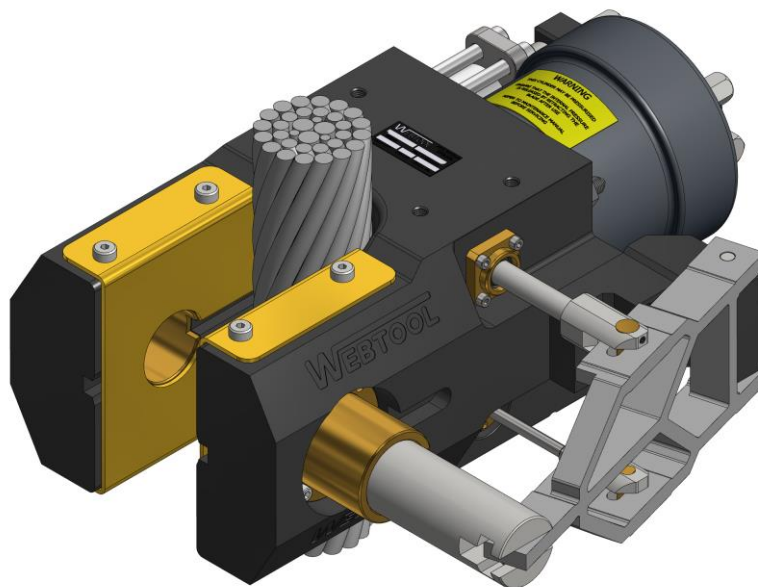

It is important that the anvil is fully closed before cutting commences, this will prevent damage to the tool. To prevent the cutting cycle from initialising before the anvil is closed, a valve has been built into the cutter. This will only allow the main cylinder to be activated when the anvil has been correctly positioned (closed fully).

Operate the main ram power port to cut the wire rope. Hold pressure until the wire rope is severed.

Please note that this tool is fitted with a factory set relief valve that opens at approx. 750 bar. Leaving the hydraulic supply running once the blade is bottomed out on the anvil will cause the relief valve to continually open and close. This is not recommended.

IMPORTANT NOTE – ENSURE THAT THE BLADE IS FULLY RETRACTED AND THAT ALL PRESSURE TO THE CUTTER IS RELIEVED BEFORE IT IS RAISED TO THE SURFACE. FAILURE TO DO THIS CAN LEAD TO A DANGEROUS BUILD UP OF PRESSURE IN THE CYLINDER.

Once the wire is severed, pressurize the main ram retract port to withdraw the cutting blade. Do not try to remove the anvil when the blade is fully extended.

If a further cut is required, the above procedure should be repeated.

TROUBLESHOOTING

If the rope does not cut through completely on the first attempt, cycle the blade by retracting it slightly and then attempting the cut again.

If the rope does not completely cut after multiple cycles of the blade, check the input pressure to the main input of the cylinder. This can be a **maximum of 200 bar** (2,900psi). Please note the tool is fitted with a 4:1 intensifier and a relief valve which will limit the output pressure to a maximum of 750 bar.

If the rope to be cut is still not severed after multiple cycles and at a pressure of 200 bar, retract the blade and then remove the anvil and return the tool to the surface for inspection of the blade and anvil. Replace if necessary.

5. AFTER USE

When the tool is retrieved from a marine environment, it should be hosed off with clean water, allowed to drain and sprayed externally with a de-watering fluid. Before storage, inspect the general condition of the tool. Particular attention should be paid to the anvil and blade. The anvil should be clean and free from any damage (a witness mark is usually seen on the anvil). The blade edge should be smooth and free from any serrations. Note that a slight ripple to the blade edge is acceptable and will not cause problems. Any minor damage can be smoothed off with an oil stone if necessary.

Please note that the tool is not designed to be left on the sea bed permanently or for long periods of time. Please refer to the manufacturer (Allspeeds Ltd) or an authorized distributor should you wish to use this tool subsea for any period over **14 days**.

IMPORTANT – DO NOT STORE THE TOOL WITH A COMPLETELY SEALED CYLINDER AS PRESSURE MAY BUILD UP DUE TO TEMPERATURE CHANGES.

6. SERVICE

IMPORTANT – ENSURE THERE IS NO HYDRAULIC PRESSURE IN THE CYLINDER BEFORE PERFORMING ANY SERVICE OR MAINTENANCE PROCEDURES ON THIS CUTTER

It is unlikely that service would be required on the hydraulic components of this tool under normal circumstances, but a seal spares kit is available if required. The only parts that would need intermittent replacement would be the anvil and blade, depending on the frequency of use, corrosive conditions and materials being cut. These parts can be ordered using the following spares reference numbers, but in addition please quote the tool serial number:

Seal Kit (main cylinder)	Part Number	995077
Wear Plate Kit	Part Number	995078
Anvil	Part Number	761286
Blade	Part Number	705062C
Blade Retaining Pin (x2)	Part Number	030648

We advise that any servicing should be carried out by an authorised distributor only.

If required, the tool can be returned to the manufacturer (Allspeeds Ltd) or an authorized distributor for servicing and testing.

If servicing is to be undertaken by the user, please see note on proof testing under SAFETY (section 1), and the following:-

- All servicing operations should be carried out in a clean environment to prevent contamination of the oil and mating components.
- Care should be taken with all mating areas i.e. threads and sealing faces, as any damage or abrasive contamination could cause galling or seizing on re-assembly.
- The cylinder is a pressure vessel and should not be drilled, machined, mutilated or damaged in any way for mounting purposes or to assist in its removal for servicing, any warranty could be invalidated by such actions (see section 9)
- The use of a Stilson wrench to remove the cylinder is not recommended as damage will occur.

7. REPLACEMENT OF THE ANVIL

To replace the anvil loosen the four screws (044308) securing the pivot pins (761225) and lever frame axle (713257). This allows the pivot pins and the lever frame axle to be removed freeing the lever frame. Pull the lever frame (713265) away from the cutter this will draw out the anvil (761286). This is fixed to the lever frame with the anvil pin (761271). Slide the lever frame down the anvil at which point the anvil pin (761271) will become visible, remove the anvil pin and then the anvil can be removed.

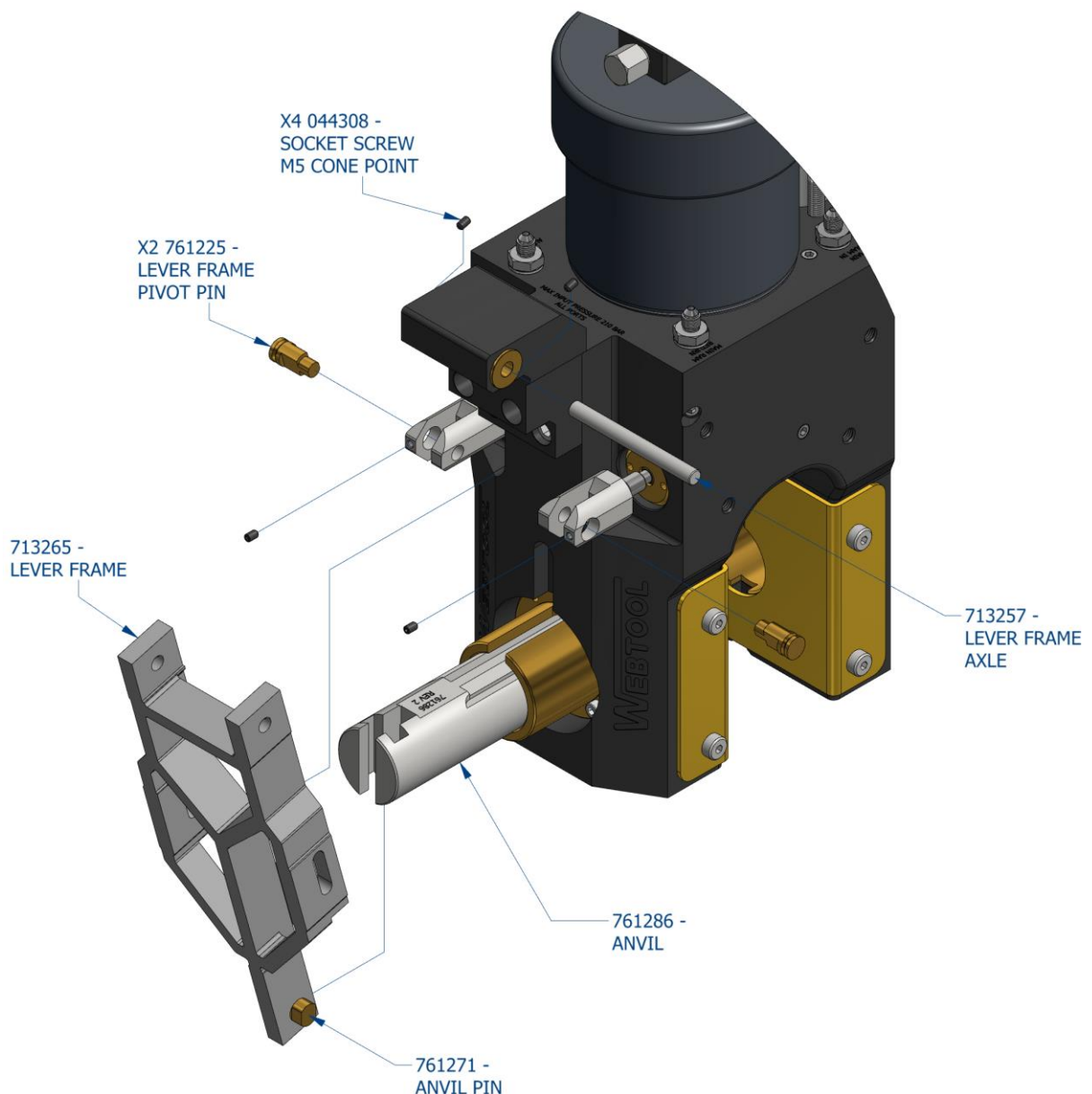

Re assembly is the reverse of the above. When assembling the two pivot pin screws, coat them with Loctite Threadlock 222 on the last couple of threads, screw down until the point engages with the groove in the pivot pin then back off a quarter of a turn. The screw provides axial retention, but the pivot pin should be free to rotate.

8. REPLACEMENT OF THE CUTTING BLADE

First remove the 8 screws (035135) securing the two wear plates (765316) and remove the anvil as described in section 7. Pump out the main ram until the two blade retaining pins (030648) can be seen and knock out the pins and slide out the blade.

Replacing the blade is the reverse of the operation described above.

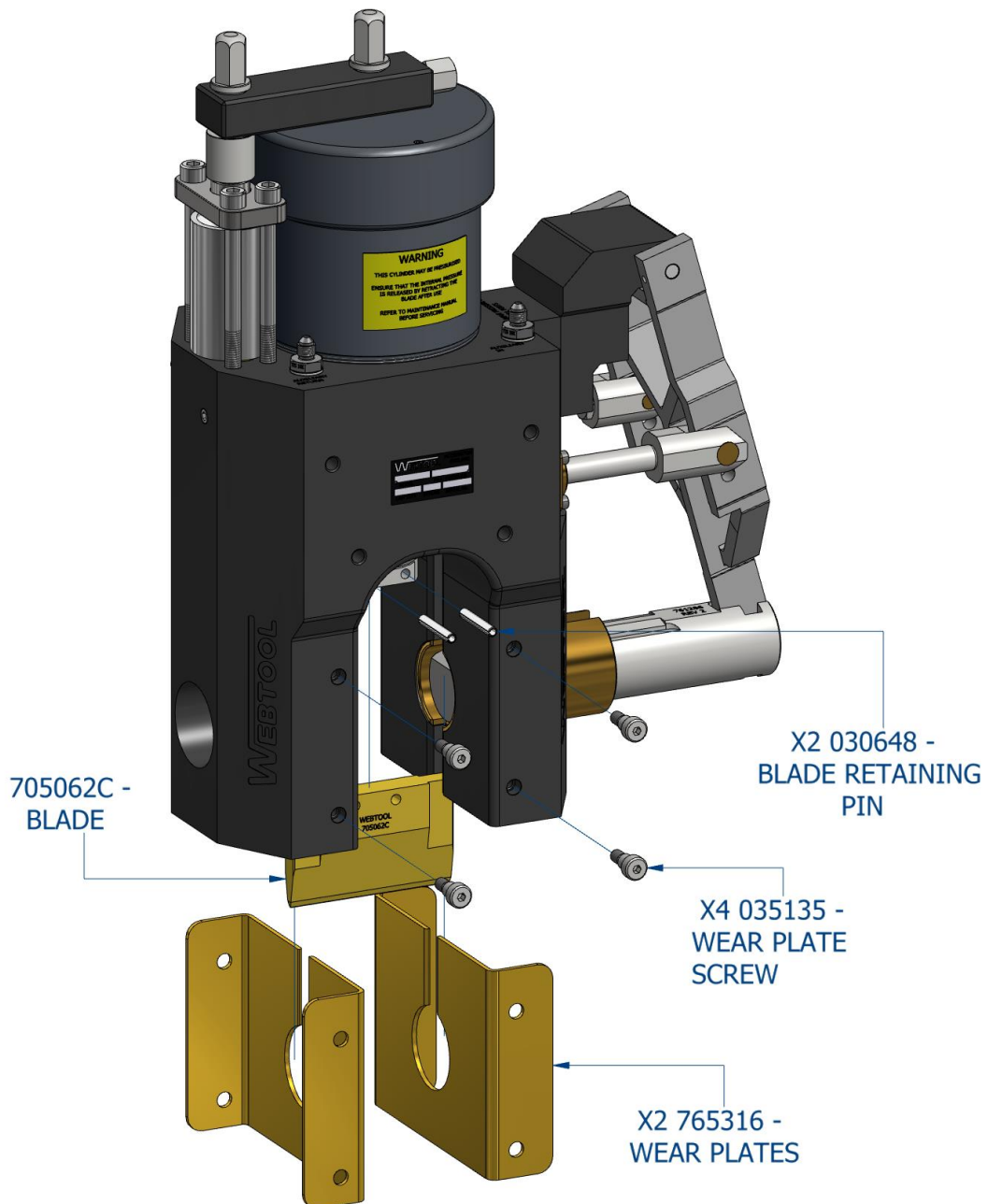

9. REMOVAL OF THE MAIN CYLINDER

First, ensure there is no pressure contained in the cylinder. Remove the collar nuts (020123) and lift the banjo bolt connector (765317) along with the bonded washers and the banjo bolt (761288). This makes removal of the cylinder easier.

Remove the two grub screws in the top of the cylinder and fasten a bar across using the two tapped holes (a cylinder assembly tool is available as an optional extra part number (SK4377A)).

The bar must be fastened in such a way that a handle is offered at either side of the cylinder, the cylinder must then be unscrewed with equal force about the centreline, providing a torque, not a moment.

Do not use a Stilson wrench to remove the cylinder as damage will occur.

Assembly is the reverse of above.

See overleaf for an exploded view of the internal cylinder components and a view of the cylinder components in their fully assembled state.

Exploded View of Internal Cylinder Components

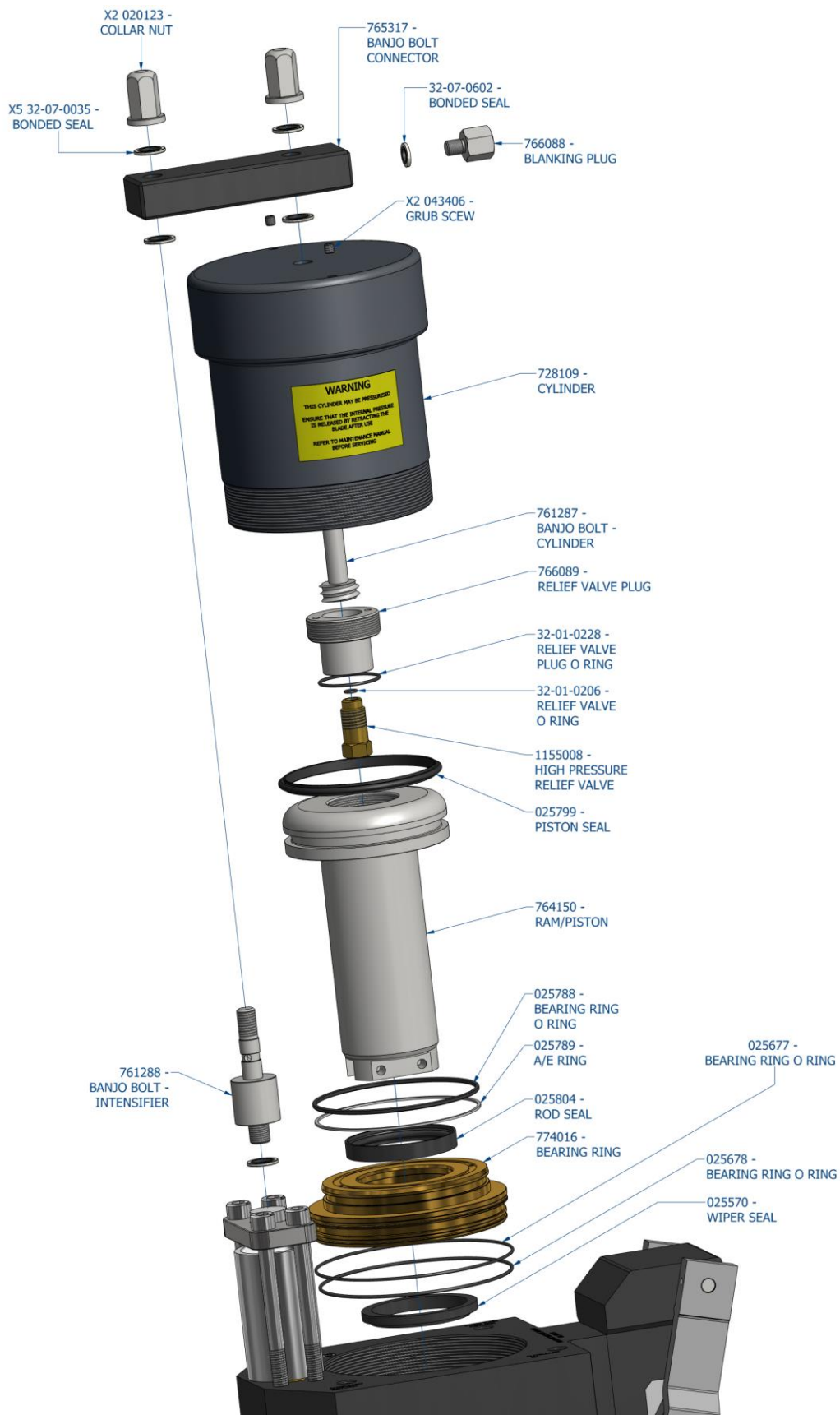

View of Internal Cylinder Components in the Assembled State

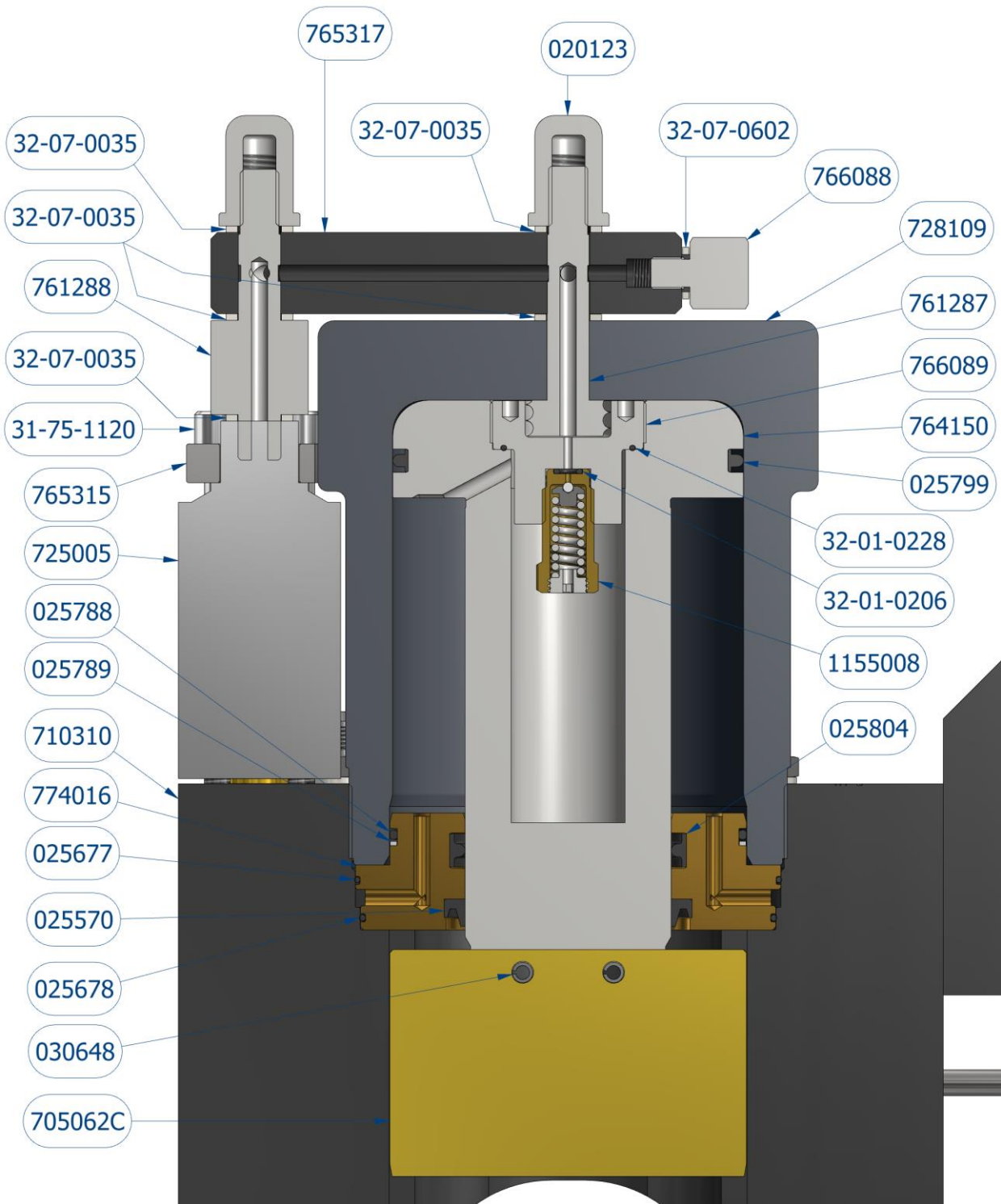

10. CHANGING THE SEALS

To remove the piston, first detach the blade by removing the two blade retaining pins. Remove the cylinder as described in section 9, this will allow the piston to be removed and the piston seal becomes accessible.

In the top of the piston is a bung which carries a relief valve. Remove the bung using the two small holes in the top. The relief valve is attached underneath. Remove it with a 17mm socket. The O Ring is located inside.

An O Ring is used to seal the underside of the bung.

When the bung and relief valve are re assembled, ensure the top face of the bung is below the top face of the piston.

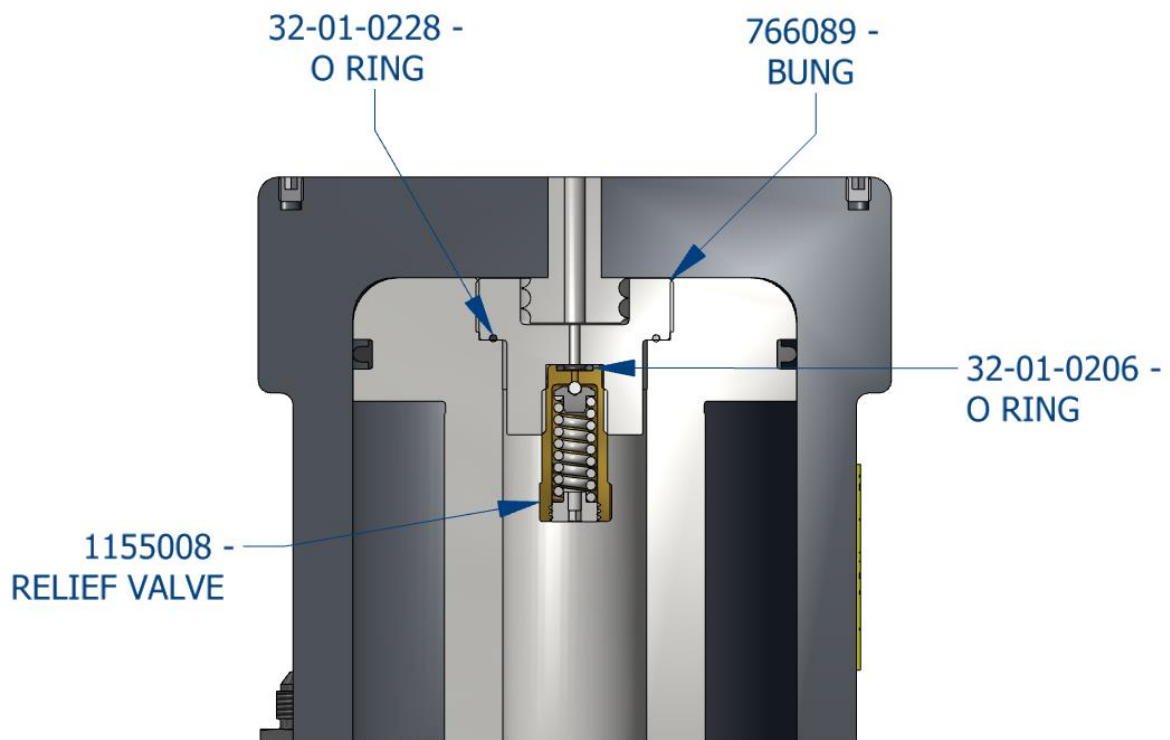

To access the seals on the auxiliary side, first remove the screws (044308) and the pivot pins (761225). The lever frame (713265) can now be moved away.

Remove the 4 screws (035052) so the auxiliary gland can be removed with the piston. Unscrew the piston from the piston fork and remove from the gland.

The internal seals are now accessible.

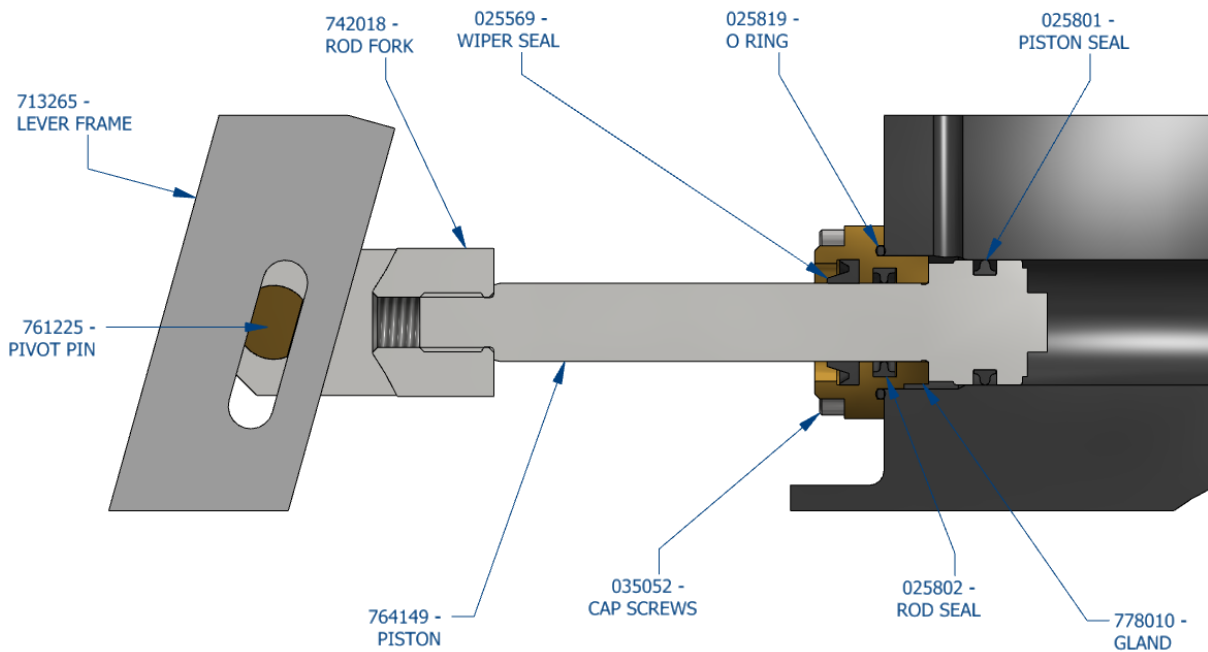

Assembly is the reverse of above.

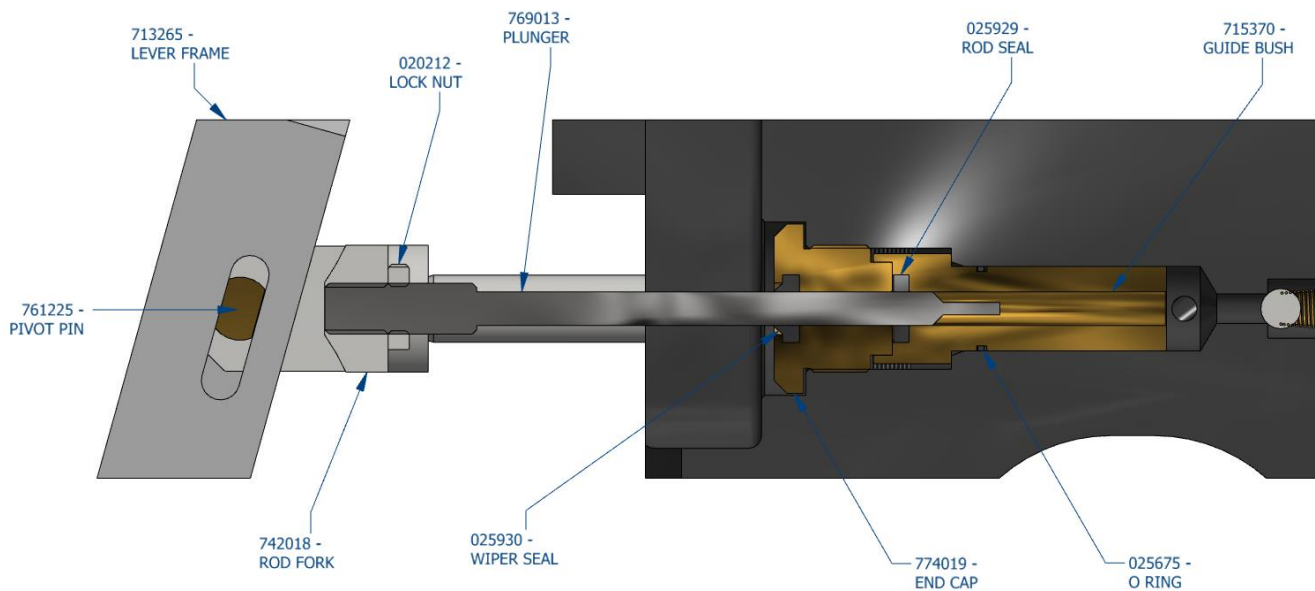

The seals on the plunger side are accessed by first removing the screws (044308) and the pivot pins (761225) the lever frame (713265) can now be moved away. Remove the plunger assembly with the piston rod fork (742017) from the body. Unscrew the plunger end cap (774019). Use a hook to remove the guide bush (715370). All seals are now accessible.

Assembly is the reverse of above. The lock nut (020212) sets the plunger (769013) in such a position that the blade cannot be activated until the anvil is almost fully home. **DO NOT** alter this setting. If this setting is disturbed the manufacturer should be contacted for details of how to re-set the plunger correctly, failure to do this could lead to a dangerous occurrence or tool breakage.

To access the seal at the opposite end to the plunger use a 1" socket to remove the valve seating cap (766085). This will allow the valve ball (704017), valve spring (788059) and bonded seal (31-07-1308) to be accessed .

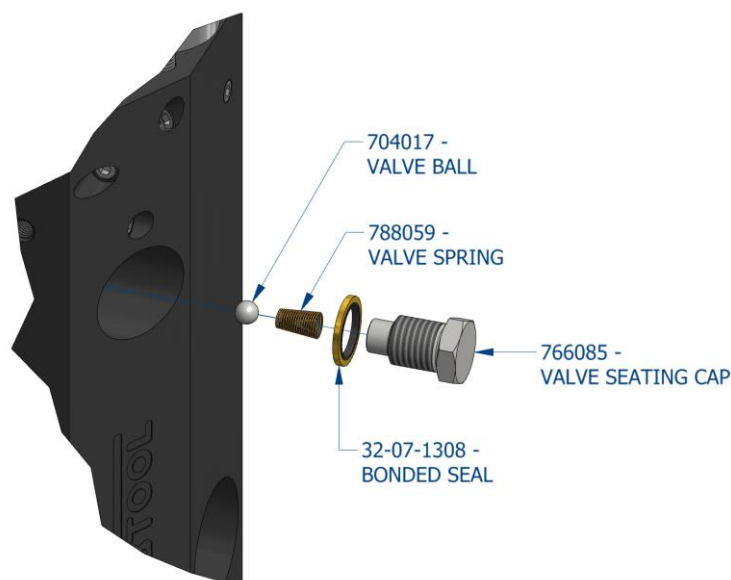

To replace the seals under the intensifier, remove the collar nuts (020123), remove the banjo bolt connector (765317) with the bonded washers and the banjo bolt (761288).

Next remove the four cap screws (31-75-1120) above the intensifier captive plate (765315). Remove the plate and the intensifier (725005) revealing the two restrictors (769012) and seals.

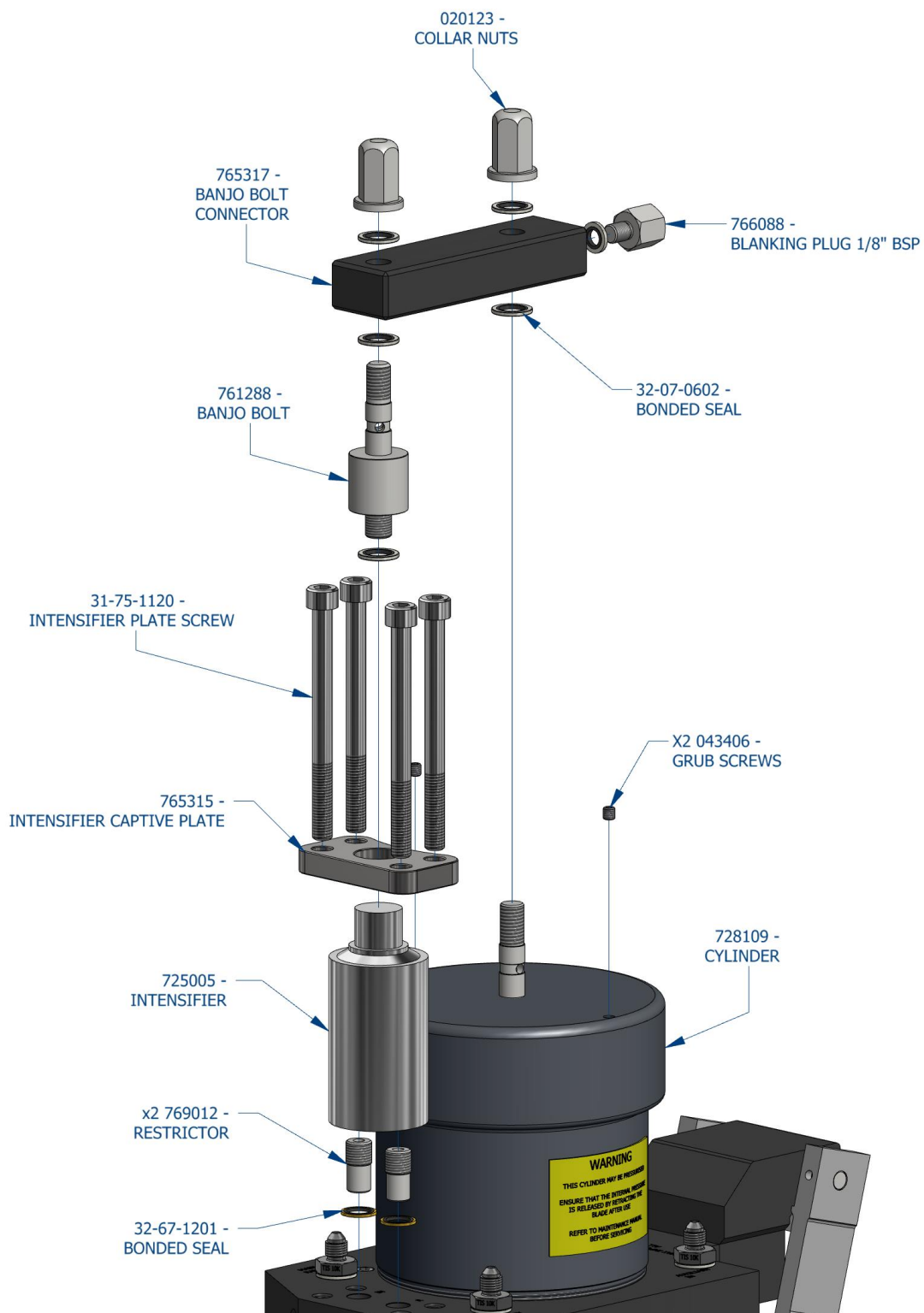

If the filters (766086) are to be changed please note the correct orientation – **IMPORTANT**.

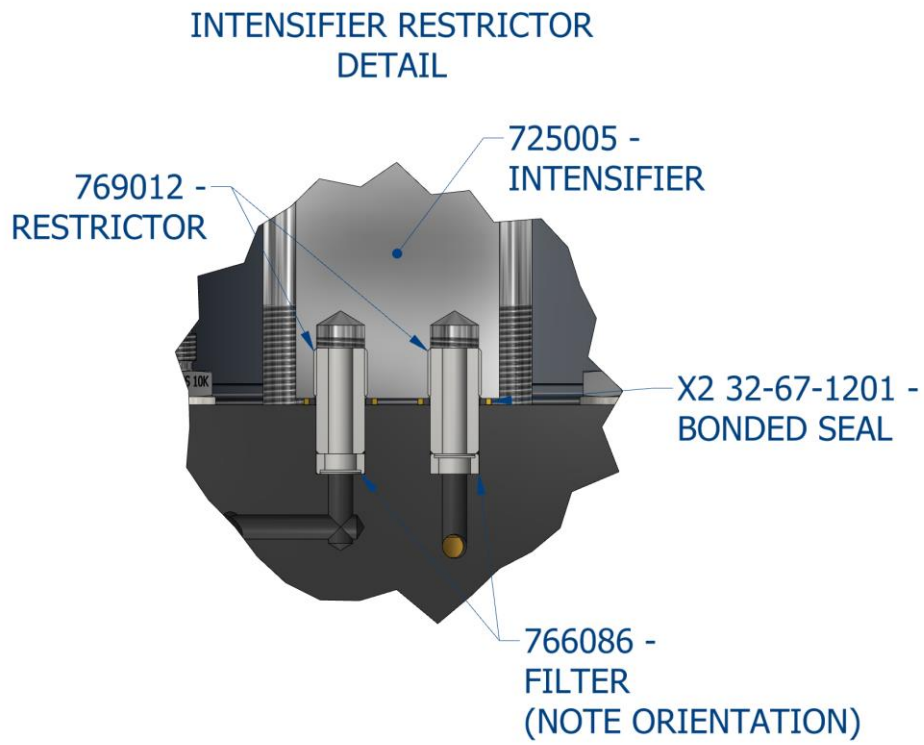

11. OVERALL CUTTER DIMENSIONS

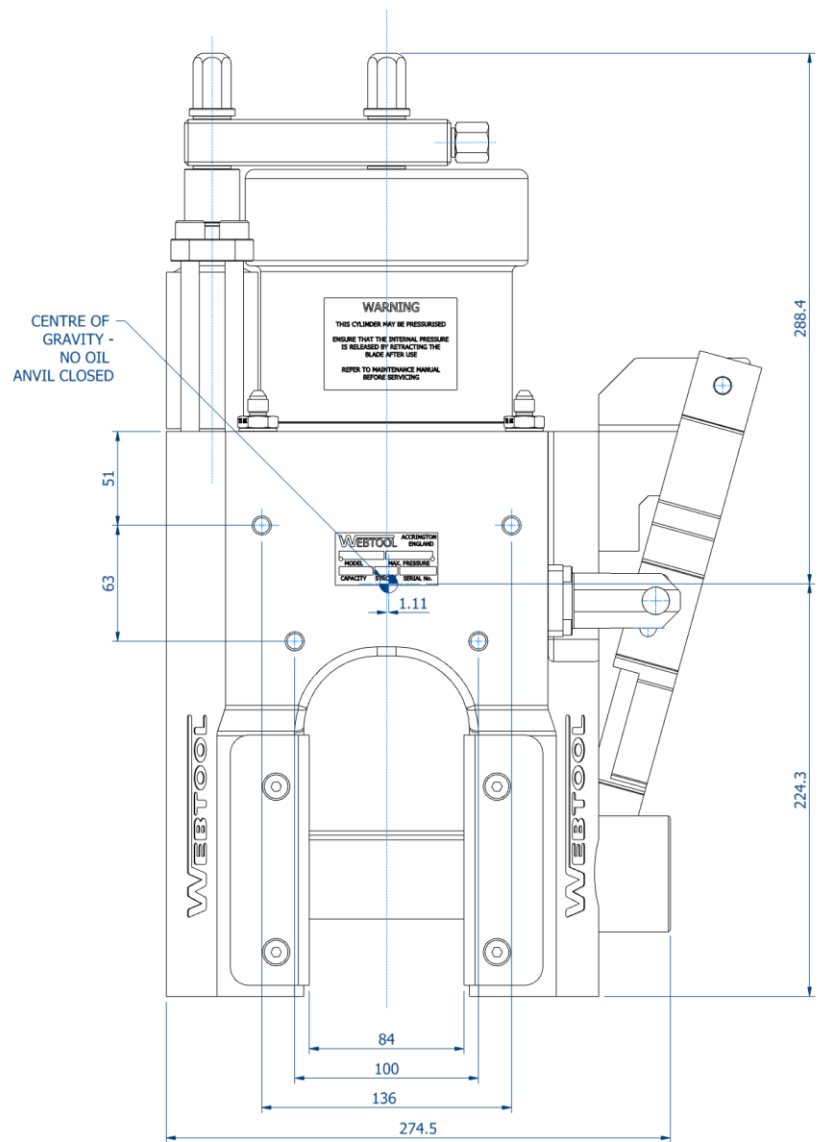
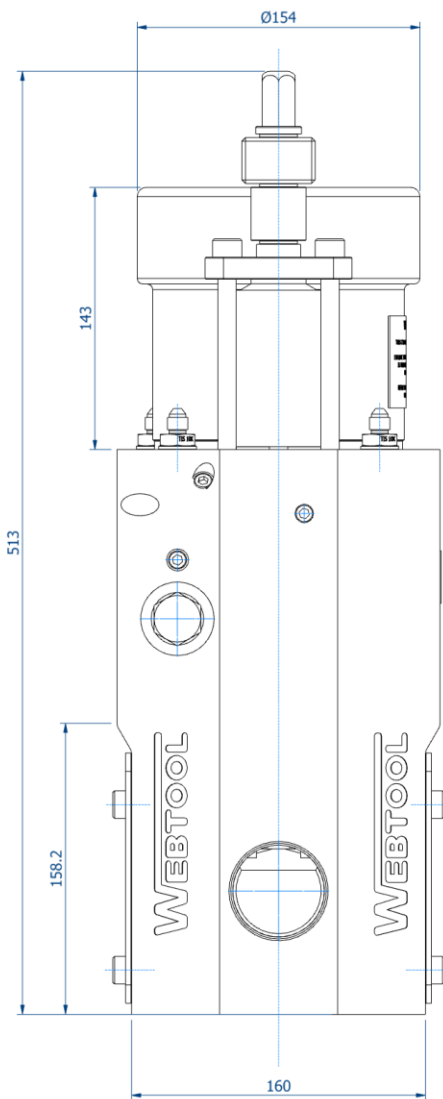
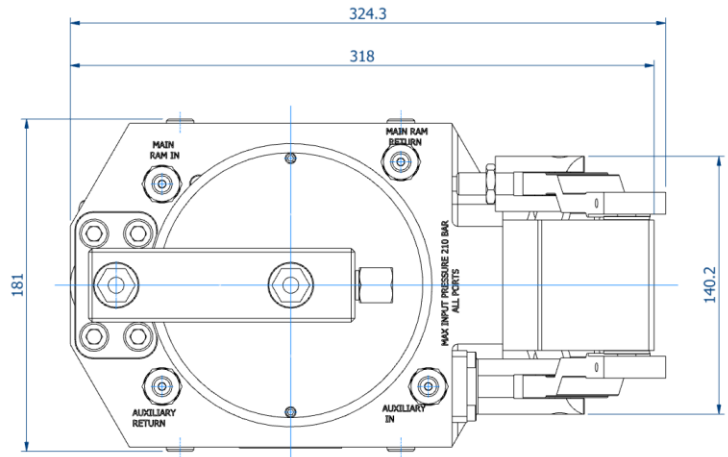

RCS75HD – Part List		980235
Part No.	Description	Qty.
710310	Cutter body	1
728109	Cylinder	1
764150	Ram	1
774016	Bearing ring	1
705062C	Blade	1
761286	Anvil	1
715367	Anvil Bush	1
761271	Anvil Pin	1
715368	Anvil Guide Bush	1
713265	Lever Frame	1
713264	Lever Frame Bracket	1
761225	Lever Frame Pivot Pin	2
713257	Lever Frame Axle	1
715369	Axle Bush	2
764149	Auxiliary Piston	1
778010	Auxiliary Cylinder Cap	1
742017	Piston Rod Fork Plunger	1
765315	Intensifier Captive Plate	1
766085	Spring Plug	1
769013	Plunger	1
715370	Plunger Bush	1
774019	Plunger End Cap	1
769012	Restrictor	2
742018	Piston Rod Fork Auxiliary Cylinder	1
765317	Banjo Bolt Connector	1
761287	Banjo Bolt Cylinder	1
761288	Banjo Bolt Intensifier	1
766088	Blanking Plug 1/8" BSP	1
766089	Relief Valve Plug	1
31-75-1120	Intensifier Plate screw	4
020123	Domed Nut M12	2
030648	Spirol Pin	2
035080	Socket Set Screw Cup Point M10 x 12 SS	7
035052	Socket Cap Screw M5 x 16 long	4
035066	Socket Cap Screw M6 x 20 long	3
044308	Screw Set Cone Point M5 x 8	4
31-63-1025	Socket Cap Screw M10 x 25 ss	4
704017	Ball valve	1
31-47-0310	Blanking Ball 5/16" dia	7
752342	Nameplate	1
725005	Intensifier HC2W-4.0-B-1	1
020212	Lock Nut M12 ss	1
788 059	Plunger Ball Spring	1
766 086	Filter	2
043 406	Socket Set Screw	2

Cutter Seal Kit		995077
Part No.	Description	Qty.
025569	Wiper Auxiliary Piston	1
025570	Wiper Ram	1
025799	Piston seal	1
025801	Seal Auxiliary Piston	1
025929	Double Acting Seal Plunger	1
025930	Wiper for Plunger	1
025802	Seal Piston Rod	1
025804	Rod Seal	1
025788	O Ring Ram Bearing Ring / Cylinder	1
025789	A/E Ring for 025788	1
025819	O Ring Auxiliary Cylinder Bearing Cap	1
025677	O Ring Bearing Ring / Body Ref 049	2
025678	O Ring Bearing Ring / Body Ref 546	1
025675	O Ring Bush Seal	1
32-07-0602	Bonded Seal	1
32-07-0035	Bonded Seal Nipples and Blanking Plug	9
32-07-1308	Bonded Seal Spring Plug	1
32-67-1201	Bonded Seal Intensifier / Body	2
32-01-0228	O Ring for Relief Valve Plug	1
32-01-0203	O Ring for Relief Valve	1
32-01-0206	O Ring for Aluminium Bronze Relief Valve	1

Wear Plate Kit		995078
Part No.	Description	Qty.
765316	Wear Plate	2
035135	Shoulder Screw M8 10dia x 10 long	8

Relief Valve Assembly		1155008
Part No.	Description	Qty.
710315	Body	1
128561	Spring	1
749010	Ball carrier	1
793083	Adjuster	1
32-01-0206	O Ring	1
704033	Ceramic Ball	1

This RCV75HD cutter is compatible with the following optional extra, not supplied as standard.

Cylinder Assembly Tool - SK4377A

This tool can be used on RCV75, RCV75HD, RCV115, RCV135, RCV155, RCV190, HCV100, HCV120, HCV250 and HCV270 cutting tools.



APPENDIX LIST:

Appendix A – miniBOOSTER® Intensifier Data Sheet (*Pages 23 & 24*)

(The following manufacturer's data sheet stipulates 200 bar maximum input pressure on all intensifier models. All Webtool™ supplied intensifiers are tested with a maximum input pressure of 210 bar)

Appendix B – Handle Data Sheet (*Page 25*)

Appendix C – Interlock Resetting Procedure (*Pages 26-29*)

Instructions for Hydraulic Booster HC2W

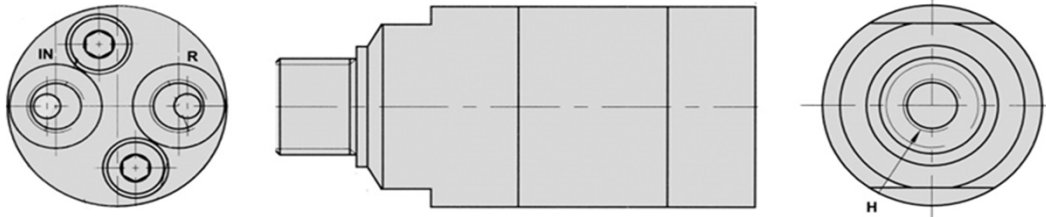

IN

DK Forskruning, Pumpetilslutning	1/4" BSP	7/16-20 UNF
UK Screwed connection, Pump connection		
DE Verschraubung, Pumpenanschluss		
FR Raccordement, Raccordement de pompe		

R

DK Forskruning, Pumpetilslutning	1/4" BSP	7/16-20 UNF
UK Screwed connection, Pump connection		
DE Verschraubung, Pumpenanschluss		
FR Raccordement, Raccordement de pompe		

H

DK Forskruning, Pumpetilslutning	1/4" BSP	7/16-20 UNF
UK Screwed connection, Pump connection		
DE Verschraubung, Pumpenanschluss		
FR Raccordement, Raccordement de pompe		

Max. Tilspændingsmoment Max Anzugmoment	Max. Tightening torque Couple de serrage max	1/4" BSP	7/16-20 UNF
DK Med stålskive	UK With steel washer		
DE Mit Stahlscheibe	FR Avec rondelle en acier	29.5 ft-lbs	29.5 ft-lbs

DK Med aluminiumskive	30 Nm	30 Nm
UK With aluminium washer		
DE Mit Aluminiumscheibe	22.1 ft-lbs	22.1 ft-lbs
FR Avec rondelle en aluminium		

DK Med skærekant	40 Nm	40 Nm
UK With cutting edge		
DE Mit Dichtkante	29.5 ft-lbs	29.5 ft-lbs
FR Avec rondelle en acier		

DK Med o-ring	20 Nm	35 Nm
UK With o-ring		
DE Mit o-ring	14.8 ft-lbs	25.8 ft-lbs
FR Avec Avec joint torique		

i	Max. flow IN		Max. flow H		Max. pressure IN		Max. pressure H	
	l/min	gal/min	l/min	gal/min	bar	psi	bar	psi
1.2	8,0	2,1	1,2	0,3	200	2,900	240	3,480
1.5	8,0	2,1	1,0	0,3	200	2,900	300	4,350
2.0	8,0	2,1	0,8	0,2	200	2,900	400	5,800
2.8	8,0	2,1	0,6	0,2	200	2,900	560	8,120
3.2	15,0	4,0	2,5	0,7	200	2,900	640	9,280
4.0	14,0	3,7	2,0	0,5	200	2,900	800	11,600
5.0	14,0	3,7	1,6	0,4	160	2,300	800	11,600
6.6	13,0	3,4	1,3	0,3	120	1,740	800	11,600
9.0	13,0	3,4	0,9	0,2	90	1,305	800	11,600
13.0	12,0	3,2	0,6	0,2	62	900	800	11,600
20.0	12,0	3,2	0,3	0,1	40	580	800	11,600

DK

HC2W kræver et pumpetryk på minimum 20 bar / 300 psi. Filtrering: Se side to. Komponenten må ikke tages i brug, før maskinen, hvori den monteres, overholder alle relevante bestemmelser i EU og EFTA.

UK

The minimum inlet pressure required to operate the HC2W is 20 bar / 300 psi. Filtration: See page two. Do not put the component to work till the machine in which it is to be mounted complies with all relevant regulations and directives by the EU and EFTA.

DE

Der HC2W funktioniert ab einem Eingangsdruck von 20 bar / 300 psi. Filtration: Siehe Seite zwei. Die Komponente nicht in Betrieb nehmen, bis die Maschine, in die sie eingebaut werden muss, alle relevanten Regulativen und Direktiven von der EU und EFTA erfüllt.

FR

Le HC2W Fonctionne avec une pression minimale de 20 bar / 300 psi. Filtration: Voir la page deux. Avant de mettre en service le composant monté, la machine doit être conforme à toutes les réglementations et directives en vigueur dans l'UE et l'AELE.

Info:

<http://www.miniBOOSTER.com>

IMPORTANT: Closed Center Valves

It is strongly forbidden to install a closed center directional valve in line with the IN & R connections of the booster.

miniBOOSTER[®] uses check valves that are leakage proof down to a few drops per minute. Even with a small amount of leakage through the check valves, high pressure can build up over time on the IN and R connection (when in closed position) and cause failure of the booster.

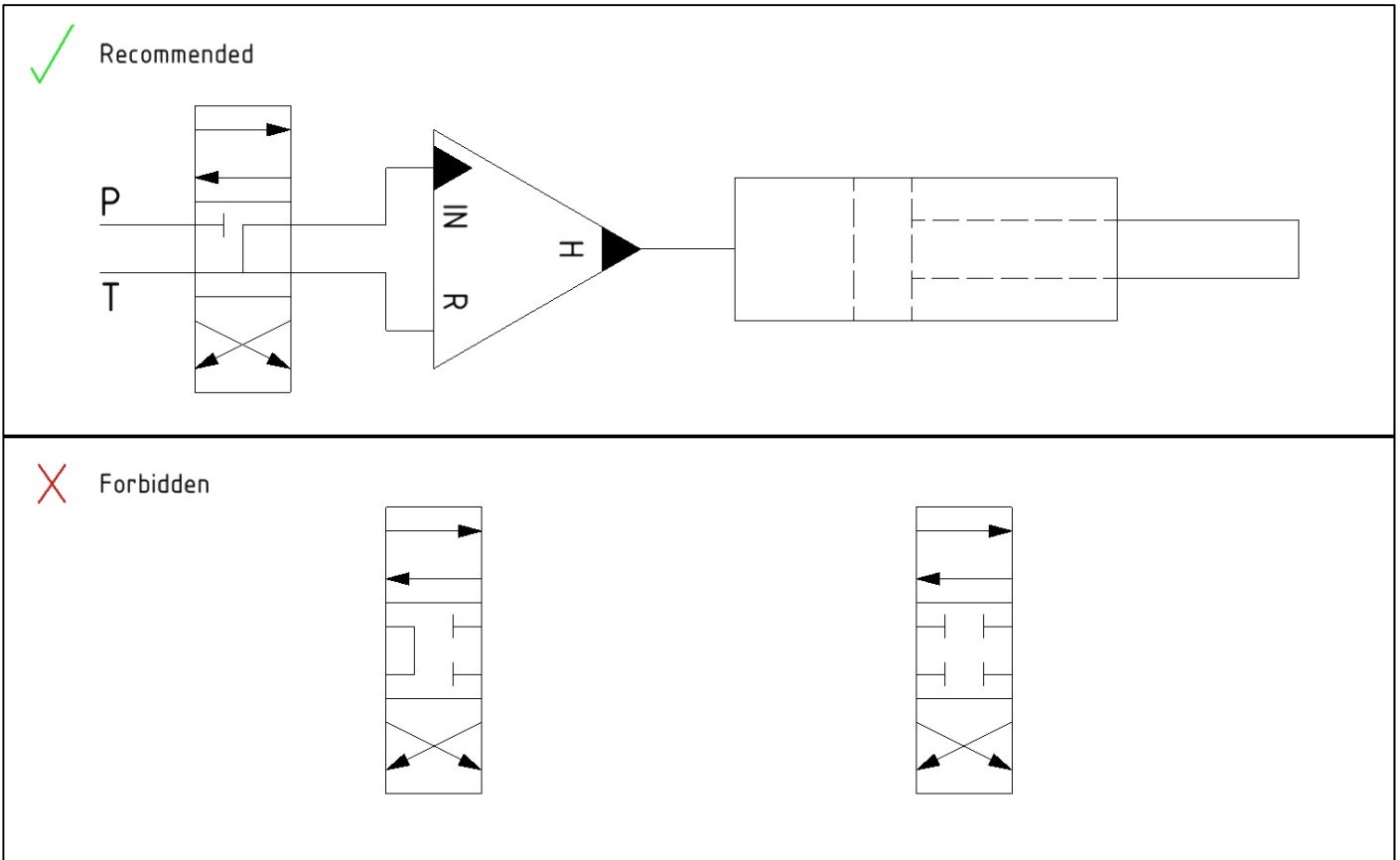

Filtration: According to ISO 4406

		0 to 140 bar 0 to 2000 psi		141 to 200 bar 2000 to 3000 psi		> 200 bar > 3000 psi	
Media		ISO Target Levels	Micron Ratings	ISO Target Levels	Micron Ratings	ISO Target Levels	Micron Ratings
Oil	> 5 cSt	19/17/14	10	18/16/13	5	17/15/12	3
Water	< 5 cSt	18/16/13	5	17/15/12	3	16/14/11	3
Water Glycol	< 5 cSt	18/16/13	5	17/15/12	3	16/14/11	3

RCV75HD – Side Handle Add On Kit Part No - 999029

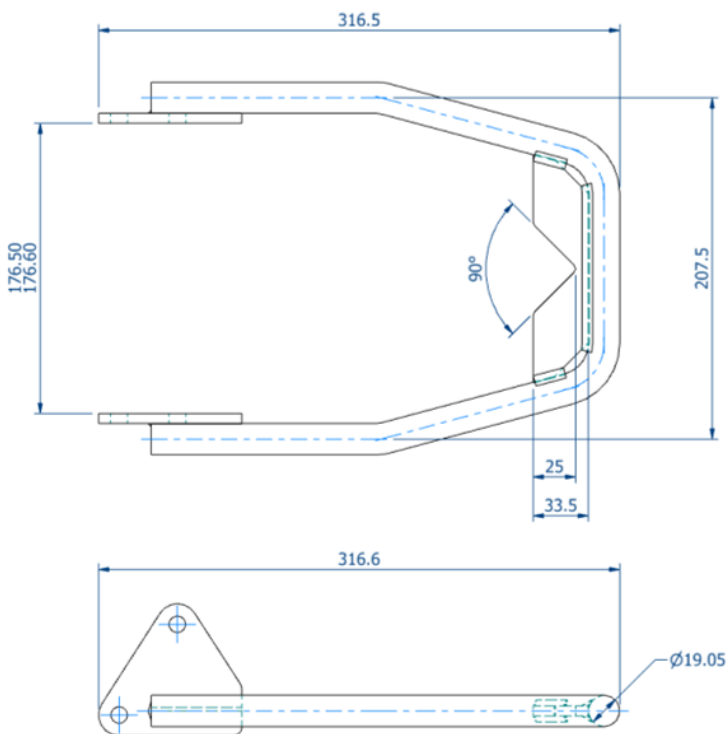
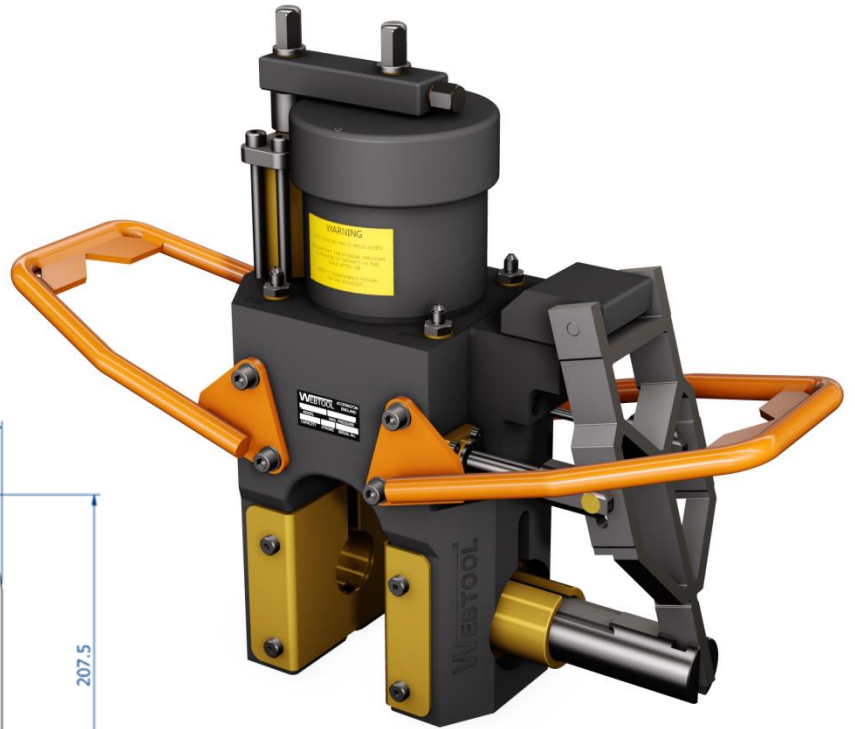

- Lightweight aluminium and stainless steel construction
- Diver or ROV operable design
- Allows quick and efficient operation
- Handle gripping point designed to be suitable for many ROV attachment arms
- Can be used at any water depth
- Coloured to RAL2004 Orange to conform with subsea standards
- Can be deployed either side of the tool to aid manoeuvrability
- Handle kit includes
 - 1x RVC75HD Side Handle
 - 4x M10 washers
 - 4x M10 cap head screws
- All made from corrosion resistant materials
- Standard handle is shown above. Bespoke and custom designs to suit special applications are available on request

Webtool – A division of Allspeeds
Royal Works, Atlas Street
Clayton-Le-Moors, Accrington, Lancashire. BB5 5LW
UK Tel: +44 (0) 1254 615 100 Fax: +44 (0) 1254 615 199

Appendix C: RCV75HD Interlock Checking and Adjustment Procedure

This procedure assumes that the RCV75HD cutter requires no other servicing or seal replacement. See RCV75HD manual for servicing and operating instructions.

Connect the Aux In and Aux Out ports to a suitable double acting hydraulic supply (Maximum 210 bar)

Connect the Main Ram In and Main Ram Return ports to a suitable double acting hydraulic supply (Maximum 210 bar)

1 Check that the anvil functions correctly.

Pressurise the Aux In port whilst leaving the Aux Out port open to tank. The anvil should close.

Pressurise the Aux Out port whilst leaving the Aux In port open to tank. The anvil should open.

In the fully closed position, the piston fork should bottom out as shown, and the end of the anvil should be approximately 26.5mm from the body.

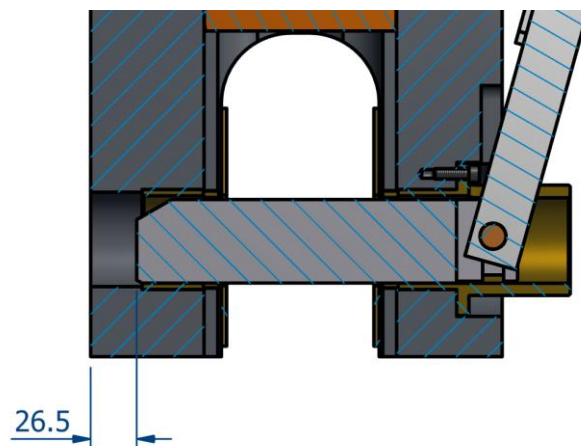
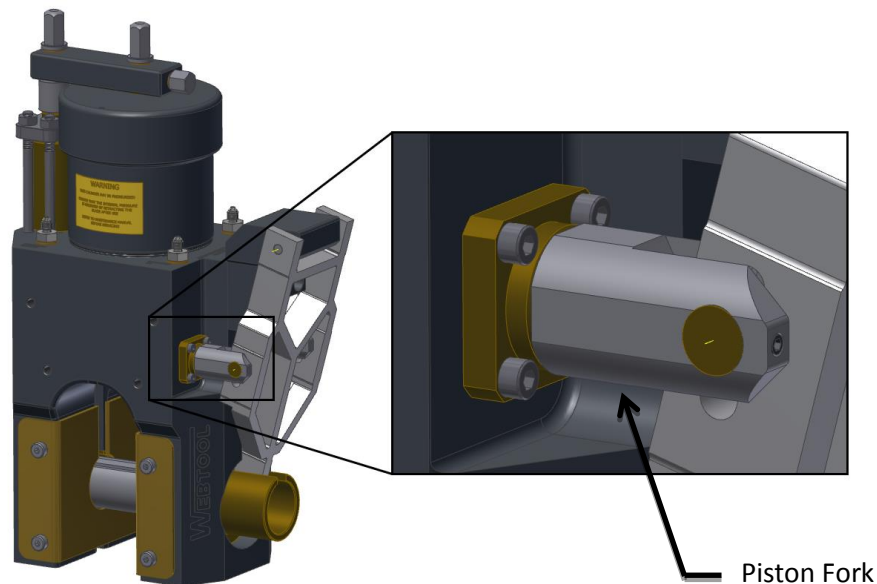

Figure 1 – Anvil closed position

2 Interlock Check

2.1 Anvil fully closed

Ensure that the anvil is fully closed as described above, and that pressure is maintained onto the Aux In port.

Pressurise the Main Ram In port, whilst leaving the Main Ram Return port open to tank.

The blade should now move towards the anvil. At this stage, do not let it bottom out on the anvil.

If the blade does not move, the interlock may not be set correctly. Go to step 3.1

Pressurise the Main Ram Return Port whilst leaving the Main Ram In port open to tank. The blade should retract.

Remove all hydraulic pressure.

2.2 Anvil Partly Open (Using Spacer)

Open the anvil by pressurising the Aux Out port whilst leaving the Aux In port open to tank.

Insert the 3mm thick interlock spacer (part number SK4839) as shown in the image below.

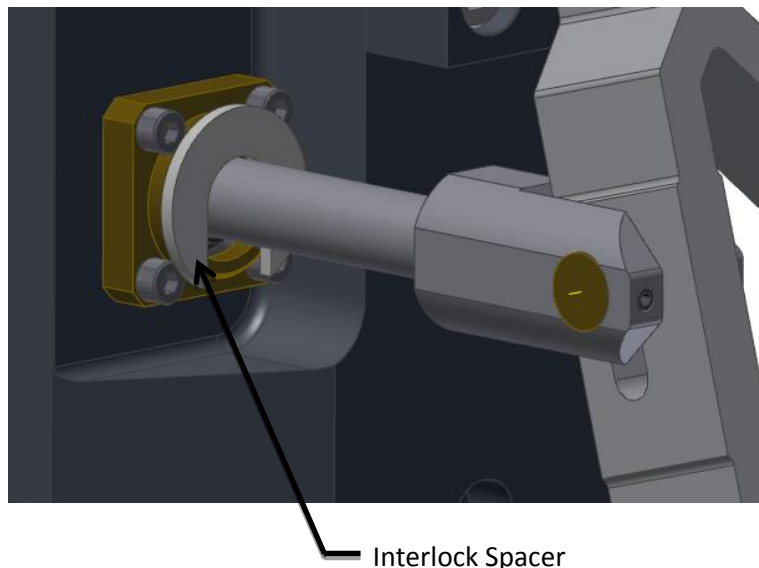

Figure 2 – Interlock spacer assembly

Close the anvil so that the piston fork bottoms out on the spacer. Maintain pressure onto the Aux In port.

Pressurise the Main Ram In port, whilst leaving the Main Ram Return port open to tank.

The blade should NOT move as the partially open interlock is preventing pressure from reaching the intensifier, and therefore the ram.

If the blade does move, the interlock is not set correctly. Go to step 3.2

3 Interlock Adjusting Procedure

Please note, this procedure should only be followed if the tests as previously described are not successful. If the interlock is functioning as designed please DO NOT adjust it.

Open the anvil fully and then remove ALL hydraulic pressure from the tool.

Loosen the lock nut as shown.

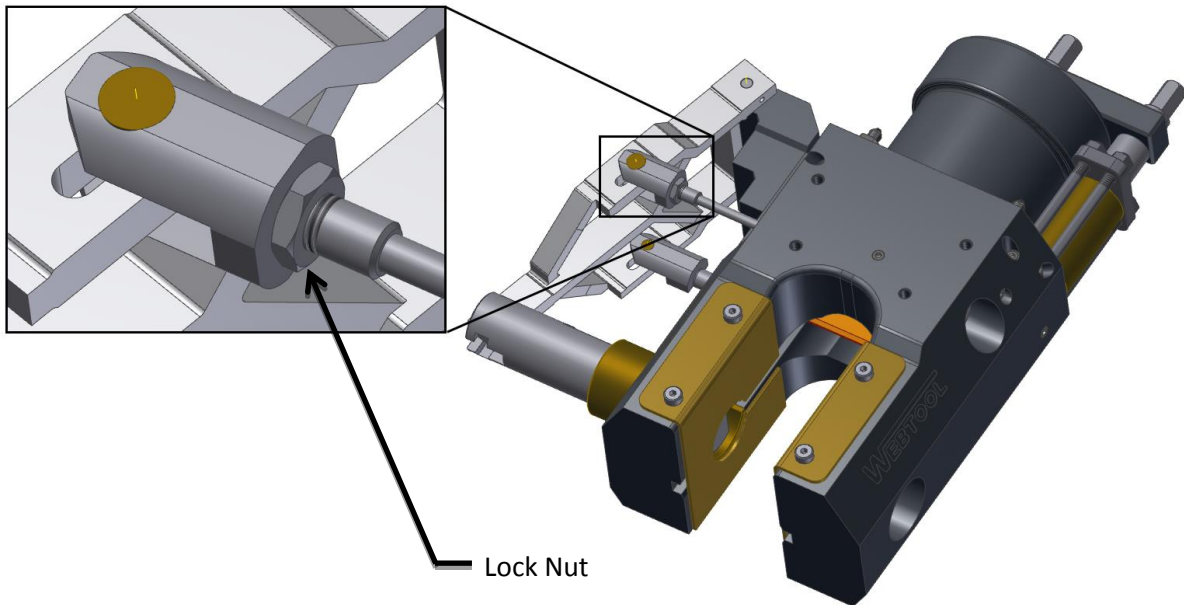

Figure 3 – Lock Nut

Rotate the interlock plunger half a turn as follows:

3.1 Rotate the plunger as shown if test 2.1 failed

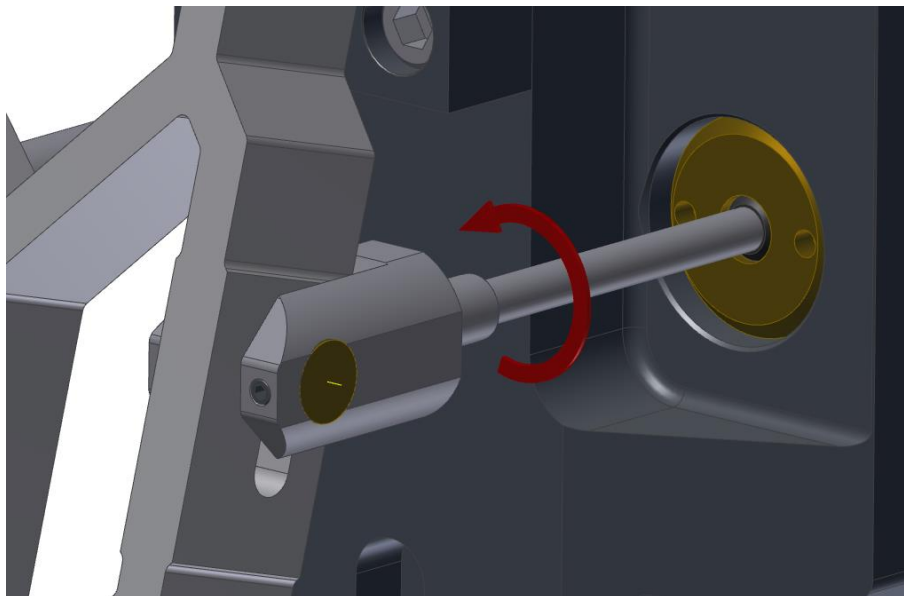

Figure 4 – Lock nut adjustment

3.2 Rotate the plunger as shown if test 2.2 failed

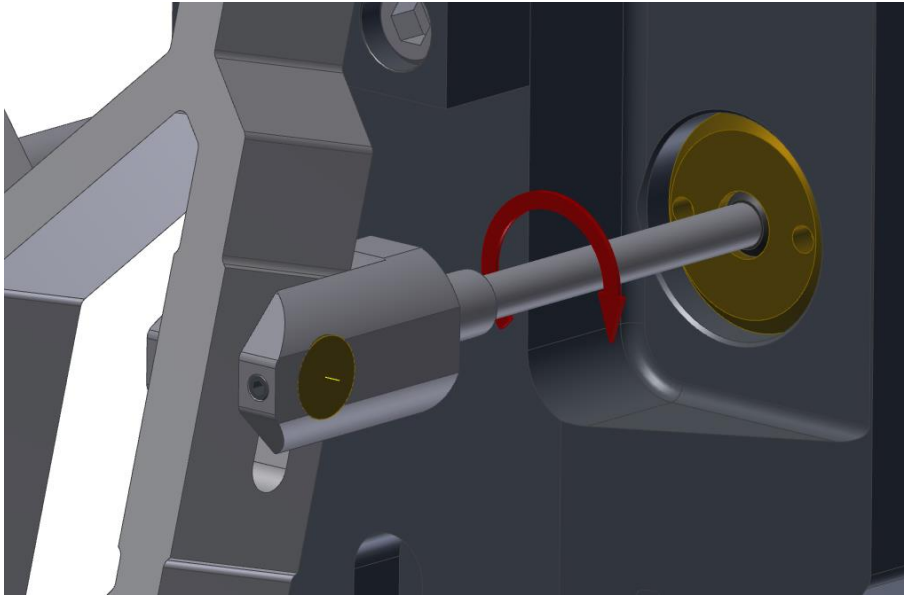

Figure 5 – Lock nut adjustment

After adjusting the plunger, tighten the lock nut and repeat tests 1 and 2. Readjust half a turn each time if necessary.



CUTTING EDGE TECHNOLOGY

Webtool specialises in engineering powerful hydraulic tools for cutting and gripping rope, cable and umbilicals.

Models designed for use in subsea environments by ROV's, and surface applications in hostile environments.

- Wire rope cutters (WCS and WCOS) – capable of cutting steel wire rope up to 75mm diameter
- Wire Rope Cutters (RCV) – capable of cutting steel wire rope up to 190mm diameter
- Cable Cutters (HCV) – capable of cutting cable, umbilical and armoured flexible pipe lines up to 330mm diameter
- Softline Cutters (SL) – capable of cutting fibre ropes in various sizes
 - Wire Rope / Cable Grippers

Application specific solutions

Our in house design and manufacturing capability means we can quickly and efficiently develop a solution to suit your particular application. Contact our engineering department to discuss how we can help.

Allspeeds Ltd, Royal Works, Atlas Street, Clayton-Le-Moors,
Accrington, Lancashire, BB5 5LW, England

T: +44 (0)1254 615100

F: +44 (0)1254 615199

E: info@allspeeds.co.uk

W: www.allspeeds.co.uk

Twitter: @allspeedsUK